

HCV and the RSPO



Report of an independent investigation into the effectiveness of the application of High Conservation Value zoning in palm oil development in Indonesia

Marcus Colchester, Patrick Anderson, Norman Jiwan,
Andiko and Su Mei Toh

Public Discussion Document

October 2009



HCV and the RSPO: report of an independent investigation into the effectiveness of the application of High Conservation Value zoning in palm oil development in Indonesia

October 2009

Acknowledgements:

This investigation was carried out by a team of volunteers paid for by their own organisations' programme budgets – Forest Peoples Programme, SawitWatch and Wild Asia. Most of the costs of the team's travel and accommodation, and of the legal research by HuMA and the costs of interpretation and translation, were born by the Forest Peoples Programme, as part of its project on Responsible Finance and Sustainable Livelihoods in Indonesia, funded by the Ford Foundation. Wilmar International also assisted substantially in helping to organise and arrange travel, providing access and accommodation within its estates in Landak and making available its HCV reports and permitting data. We particularly acknowledge the help of Simon Siburat, including his comments on a first draft of this report. We are also grateful to all those who made time to be interviewed including Pak Derom (GAPKI), Pak Daud Dharsono (Sinar Mas), D P Arthibahn, Sunny Goh, S. Sinnaya (Group GM of Wilmar Kalbar), Agus Pamungkas (Wilmar Kalbar), Edrin Moss (RSPO coordinator, Wilmar Kalbar), Iqbal Rayhani (Wilmar Kalbar), Petrus Silaban (Wilmar Kalbar), Bernard Ho (GAPKI), Firman (GAPKI), Gary Paoli and Aisyah Sileuw (Daemeter Consulting), Reza Azmi (Wild Asia) and Pep George (ProForest). Thanks are also due to Leo Nikom for driving us and helping with photocopying and logistics. The authors alone are responsible for the interpretations and recommendations presented in this report.

Sections of this report may be reproduced provided that acknowledgement is made to the authors and Forest Peoples Programme, SawitWatch, Wild Asia and HuMa



© Forest Peoples Programme, 2009

The Forest Peoples Programme is a company limited by guarantee (England & Wales) Reg. No. 3868836.

UK-registered Charity No. 1082158.

It is also registered as a non-profit Stichting in the Netherlands.

HCV and RSPO: results of an investigation

Contents:

Executive Summary	4
1. Introduction	6
2. High Conservation Values and the RSPO	6
2.1 The HCV concept	
2.2 HCV requirements in the RSPO P&C	
2.3 HCV requirements in Indonesia national interpretation	
2.4 HCV Toolkit for Indonesia	
3. Methods	11
4. Findings	12
4.1 The legal framework	
4.2 The reallocation of permits	
4.3 Financial incentives	
4.4 Land acquisition: long term implications for communities	
4.5 HCV assessments	
4.6 Management options	
5. Conclusions and Recommendations	31
Annexes	36
1 Terms of reference	
2 Composition of the research team	
3 Legal review	
4 Landak District Regulation No. 10 of 2009	

Executive Summary:

The RSPO procedure, as set out in its 'Principles and Criteria' and the various national interpretations, seeks to encourage voluntary efforts by companies to identify and avoid clearing areas of 'high conservation value'. HCV areas include areas critical to maintain rare and endangered species, ecosystems and landscapes, secure essential environmental services and areas critical to local livelihoods and cultural identities. Companies are also expected to manage their plantations so that all these high conservation values are maintained or enhanced. The overall aim is to deflect palm oil expansion away from these valuable areas. In August 2009 preliminary reports from the field suggested that these objectives were being frustrated in Indonesia and it was agreed that an investigation should be carried out to examine the extent of the problem and suggest how it might be addressed.

This report presents the results of this investigation. Based on a detailed legal review and a field study of the situation in West Kalimantan, the main conclusions of this study are the following:

- *Extensive HCV areas identified by RSPO member companies are not being protected but are being re-allocated by local government to other companies:* Some RSPO member companies have invested a considerable amount of resources, time and effort in identifying High Conservation Value (HCV) areas and areas important for local livelihoods. These efforts have delayed land acquisition, clearance and planting. These delays have meant that companies have exceeded the permitted three-year period for preparing their areas prior to them securing their final leases. Overriding appeals by the companies, local government officials have chosen to terminate these permits and/or restrict the areas permitted to these companies and have re-allocated parts of these areas to other companies including non-RSPO members, some of which are allegedly clearing lands including HCV areas.

Although some of the delays have arisen from the novelty of RSPO procedures and the need to build up capacity in both consultancies and company management, it is likely that similar situations will arise in future. Normal permitting procedures are anyway onerous and the additional requirements of compliance with RSPO standards are time-consuming.

- *HCV areas are being relinquished by companies* The study also found that RSPO member companies are choosing to relinquish substantial HCV areas identified in their initial permitted areas and are handing these HCV areas back to the government. They are doing this to avoid burdensome taxation, to reduce the size of the corresponding areas that they are obliged to develop as smallholdings and to make it easier to comply with the RSPO requirement that they manage HCV areas that are within their permits. However, HCV areas so released by the companies can be reallocated to other companies, who may not be RSPO members and who have no obligation to maintain or enhance HCVs.
- *HCV areas are not legally secure* Indonesian law makes no explicit provision to protect HCVs although the study identified a number of laws and regulations which could *potentially* be used to strengthen HCV protection. However, **the laws as current applied do not secure**

HCV and RSPO: results of an investigation

HCV areas. When companies hand back HCV areas identified in their *izin lokasi* to the government, these areas are not given any legal protection and can be allocated to third parties. Areas which the companies identify as under community ownership, or which are essential or critical to local livelihoods (HCV 5) and critical to cultural identity (HCV 6), are considered community lands. These areas may also not be included in final company leaseholds (HGU). Because community lands are not secured by law, these HCV areas are also vulnerable to reallocation to third parties. When HCV areas are retained within HGUs but are not planted, they may be secure for the duration of the permit (mean of 30 years, subject to renewal), but at the expiry of the lease these areas revert to the State, are not automatically accorded any legal protection and are then available to be allocated to other companies again. Areas of importance to communities, including HCVs 5 and 6, that were retained in HGU revert to the State and not the community at the expiry of the lease and are also then not secure.

In sum the intended result, that the application of the RSPO standard will secure HCV areas, is being frustrated by the ill-fit between the RSPO process and the policies, laws, regulations and procedures of the Indonesian government.

The report makes a number of specific recommendations on how this situation can be remedied: by amending laws and regulations, by changing the way existing procedures are applied, by providing additional information to local authorities so they apply their discretionary powers more judiciously and by improving the guidance given to operators in the RSPO Standard, the National Interpretation for Indonesia and the Indonesian HCV Tool Kit. These are offered more as recommendations for discussion than prescriptions for next steps.

It is also recommended that RSPO tasks one of its sub-committees or working groups to deliberate these recommendations, suggest ways forward and assess how widespread these legal and procedural obstacles to compliance with the RSPO P&C are, not just in Indonesia but also on other palm oil producer countries.

1. Introduction:

In August 2009, Forest Peoples Programme was informed by local NGOs and community organisations in Indonesia that High Conservation Value areas, that were being set aside for community use or conservation in companies' preliminary permits, were being excised from companies' concessions and being handed over to other companies for clearance and oil palm planting. If these reports were true – and the details obviously needed checking – one of the main purposes of the RSPO seemed to be in jeopardy.

In communication with the Executive Board of the Roundtable on Sustainable Palm Oil (RSPO) and the High Conservation Value Resource Network (HCVRN), the Forest Peoples Programme and other NGOs offered to carry out an investigation of the situation. This was warmly endorsed by members of the RSPO Board and HCVRN, and it was agreed that this investigation should coordinate with the RSPO secretariat and the companies involved, including in particular the Indonesia Palm Oil Producers Association (GAPKI), which is also a member of the RSPO Executive Board.

This report summarises the findings and preliminary recommendations of this investigation.

The main finding is that, indeed, these reports are basically true, even though some of the details in the first rumours had been misconstrued. Areas that are important for maintaining HCVs, identified in company-sponsored assessments, **are** being excised from companies' permits and **are** being handed over to other companies. There is an ill fit between how the RSPO imagines high conservation values should be 'maintained and enhanced' and what is possible or secure under the current Indonesian system for zoning lands and allocating them for palm oil development.

2. RSPO and HCV:

2.1 *The HCV concept:*

The High Conservation Value Forest (HCVF) concept was developed in 1999 by the Forest Stewardship Council, where it was included as Principle 9 in its Principles and Criteria for "sustainable forest management". It was developed in recognition that certain forest areas have critical biological, ecological, social or cultural values – they may provide basic needs for local people, provide essential ecosystem services, or contain or support threatened or endangered habitats or species. These values may be of importance at the local, national, regional or global scale.

These critical values may conflict against each other, and clash with development pressures. The HCVF framework provides a structure where forest areas with these critical values are identified prior to any changes in land use or development. Once identified, appropriate management options can be developed and implemented to maintain or enhance these important values.

HCV and RSPO: results of an investigation

From its inception within the FSC framework, the concept has grown in definition and use, most evidently in RSPO, and adopted for responsible lending policies by several financial institutions. With the expansion of its use, the focus on “forest” in HCVF was dropped, recognising that non-forest natural ecosystems can also be of high conservation value.

In terms of RSPO, the inclusion of HCV in the Principles and Criteria (P&C), especially in regards to new plantings, cannot be overstated. It is meant to identify areas, in a participatory manner with local communities and other relevant stakeholders, that are suitable for conversion to oil palm development and which areas are not, so that oil palm plantings do not overlap or encroach on lands with critical values as defined in the HCV toolkit. In essence it provides guidance for plantation management on appropriate land-use and conservation planning and management that was largely absent in the way oil palm plantations normally operated. This had led, in many cases, to serious conflicts between plantation companies and local communities, as had been well documented elsewhere.¹

In summary, there are three main steps in the HCV process, also applicable to the application in oil palm development, summarised as follows²:

1. Identification of HCVs present, leading to identification of HCV management areas and proposals of management prescription to maintain or enhance these areas.
2. Development and implementation of HCV management plan
3. Implementation of a monitoring programme to assess effectiveness of the HCV management plan.

The HCV process becomes a continuous process due to the inclusion of the monitoring step. The early stages of HCV assessment, i.e. identification and developing management recommendations take many months, starting by months of preparation and planning, followed by weeks of fieldwork (depending on size and area of concession), months of analysis, and discussions with relevant stakeholders (especially local stakeholders). After which the recommendations will again be consulted with stakeholders to reach agreement on areas that will be protected, and the management and monitoring regime required.

¹ M. Colchester, N. Jiwan, Andiko, M. Sirait, A. Y. Firdaus, A. Sarambo, H. Pane, 2006, *Promised Land: Palm Oil and Land Acquisition in Indonesia – Implications for Local Communities and Indigenous Peoples*, Forest Peoples Programme and SawitWatch, 2006, *Ghosts on our Own Land Oil palm smallholders in Indonesia and the Roundtable on Sustainable Palm Oil*, M. Colchester, W. A. Pang, W. M. Chuo and T. Jalong, 2007, *Land is Life: Land Rights and Oil Palm Development in Sarawak*, Milieudefensie, Lembaga Gemawan and KONTAK Rakyat Borneo, 2007, *Policy, practice, pride and prejudice*, CIFOR document and Life Mosaic document, Friends of the Earth England, Wales and Northern Ireland, 2005, *Greasy palms; The social and ecological impacts of large-scale oil palm plantation development in Southeast Asia*, CIFOR, 2009, *The impacts and opportunities of oil palm in Southeast Asia: What do we know and what do we need to know?*, Friends of the Earth, Life Mosaic and SawitWatch, 2008, *Losing Ground - The human rights impacts of oil palm plantation expansion in Indonesia*

² For details, see *Good Practice Guidelines for HCV Assessments: A practical approach for practitioners and auditors*, ProForest

2.2 HCV requirements in RSPO P&C:

The requirements for HCV appears twice in the generic RSPO P&C, in Criterion 5.2 with regards to the requirement for the identification and management of rare, threatened or endangered species and high conservation value habitats in existing plantations; and in Criterion 7.3, on new plantings since November 2005, where it is stipulated that any primary forest or areas required to maintain or enhance any HCVs are not cleared for new plantings.

It is for new plantings that the requirements of HCV studies are most crucial. **HCV assessments must occur well prior to any land clearing, this is established in Criterion 7.3 of the generic P&C, which were adopted in 2005.** Very simply, the Criterion states, ‘New plantings since November 2005 have not replaced primary forest or any area required to maintain or enhance one or more HCVs’.

During the pilot implementation period of the RSPO³, companies considered the HCV requirements too difficult and time constraining to implement, especially when applied to huge hectares. The companies also raised concerns over the lack of government engagement in the HCV process, especially regarding their responsibility with respect to HCV areas that are not subsequently planted. There is also no specific guidance for how to manage areas vital to maintaining or enhancing HCV in or alongside oil palm plantations.

At the same time, NGOs raised concerns that companies may be going ahead with the development of new plantings without properly understanding or applying the RSPO’s requirements on HCVs and land acquisition. The RSPO responded by setting up a working group to develop a ‘new plantings procedure’. It sets out a system which RSPO companies must follow prior to the development of new plantings and re-plantings (if relevant to the guidance set in respective national interpretations), including requirements for making available public summaries of HCV assessment for public comment. The new procedure, however, has yet to be publicly announced.

2.3 HCV requirements in Indonesia:

Although it has been widely quoted in media articles about HCV that Indonesia is amongst those countries that have now incorporated HCV into spatial planning, in reality there is **no requirement** in Indonesian law and land use planning procedures for HCV assessments.

However, various HCV assessments have been carried out in Indonesia, both at the concession level of plantations and logging operations, as well as a handful of landscape level assessments that were conducted in Papua, Riau and West Kalimantan provinces. These were NGO initiatives to try to engage local governments to incorporate HCV findings in their planning processes and to support landscape level

³ The RSPO criteria and guidance underwent a pilot implementation period between November 2005 and November 2007. The objective of this period is to enable the field-testing of the criteria, and to improve the guidance. During this period, National Interpretation Working Groups of each country were meant to develop their respective NI documents.

HCV and RSPO: results of an investigation

conservation efforts, such as the Heart of Borneo initiative in West Kalimantan by WWF.

With regards to HCV requirements in Indonesia's national interpretation of the RSPO P&C, the main difference as compared to the generic RSPO P&C, is with regards to the indicators and guidance of Criterion 7.3, particularly the timeline for HCV requirements for new plantings.

The generic P&C requires that any new plantings after November 2005 should not have replaced any HCV areas. Despite this timeline, some RSPO member companies had cleared HCV areas during the pilot implementation period between November 2005 and November 2007.

The Indonesian National Interpretation Working Group (INA-NIWG) was also deliberating their draft national interpretation guidelines during this period. As seen in the draft dated September 2007 for the endorsement of the NI by the RSPO Executive Board, the INA-NIWG proposed to change the timeline for HCV requirements for new plantings to November 2007,⁴ i.e. the HCV identification requirement would not be applicable for companies that had established plantings between November 2005 and November 2007 for which HCV identification was not undertaken. This was not approved.

The final EB-endorsed NI, dated May 2008,⁵ eventually included a compromise in the guidelines, allowing companies that had cleared HCV areas during the pilot implementation period to be still eligible for certification, provided that those cleared HCV areas are taken out of the company's certifiable area. In addition, companies affected will need to comply with a compensation mechanism, once a mechanism has been identified and agreed upon. At time of writing, RSPO has not made any announcements regarding this.

Further to these additions to the guideline for Criterion 7.3, the Indonesian NI contains additions to the Major indicator, which states that new plantings within November 2005 and November 2008 must be in compliance with existing regulatory requirements relating to the management of social and environmental impacts, and accord with the legal requirements of 'spatial planning' (as the land use planning process in Indonesia is called).

2.4 HCVF Toolkit for Indonesia

The original guideline for the interpretation of HCV for Indonesia was developed in 2003 based on the generic Global Toolkit produced by ProForest. As this first toolkit was deemed to be deficient in a number of areas (e.g. insufficient focus on social issues, the lack of stakeholder approval of the toolkit, etc), an effort to coordinate the revision of the national interpretation was begun in 2006, initiated by HCV users, in a

⁴ See Final Draft of the National Interpretation of the RSPO P&C for Sustainable Palm Oil Production, Republic of Indonesia, September 2007; and the Final Document (for RSPO EB approval) of the same, dated November 2007.

⁵ See Final Document of the National Interpretation of the RSPO P&C for Sustainable Palm Oil Production, Republic of Indonesia, dated May 2008, as endorsed by the RSPO EB.

HCV and RSPO: results of an investigation

“consortium of NGOs” that included the Indonesian Resource Institute and Daemeter Consulting, which led the process, along with The Nature Conservancy, Tropenbos International Indonesia, WWF, Conservation International, Fauna Flora International and the Rainforest Alliance. The process took 18 months and in particular it addressed the original gaps by extending its applicability to other sectors other than forest management, and increasing stakeholder participation in the revision process.

The revised toolkit, finalised in June 2008, serves as a practical guide and setting a standard protocol for the identification of HCVs in Indonesia. This is achieved by:

“(i) explaining the required steps of an HCV assessment in clear and detailed terms, (ii) defining rights and responsibilities of parties involved, and (iii) providing guidelines concerning minimum standards of data collection to produce quality outputs in an efficient manner.”

The toolkit is not meant, however, to be a guide on HCV management or monitoring. Where it provides management recommendation guidelines for each of the six HCVs, it does so in broad generic terms for consideration (which stresses stakeholder consultation) rather than to impart detailed management requirements.

In terms of the social values and expanding its use beyond natural forest management systems, the discussions during the revision process focussed on “whether the ecosystem is natural (i.e. terrestrial or aquatic) or not for meeting local communities’ basic needs.” The stakeholders in the revision process reached consensus that HCV 5 will only take account of areas under ‘natural ecosystems’. Anthropogenic ecosystems (e.g., rice fields, rubber gardens) were assumed to have individual owners, hence the responsibility of management of these areas should remain with the landowner. It was felt that the company or oil palm developer should not have the right to prescribe how private lands should be managed.

In the Indonesian toolkit, *tembawang*⁶ and rubber agroforestry areas are considered as HCV because they have high communal and cultural values and they are also critical for community subsistence and livelihood. Rice fields and other agricultural areas are not considered HVC 5, although these areas are also crucial for subsistence and livelihoods. The toolkit states:

It is important to emphasize that agricultural areas, such as rice fields and vegetable gardens, are not formally included as part of HCV 5. This said, the assessor is responsible for mapping not only HCVA 5 but also agricultural areas, because these areas are extremely important for meeting basic needs of local communities. They are not considered HCV 5 because such areas do not represent forest or other natural ecosystems as intended by this HCV. Strictly speaking:

An area mapped as community agricultural land does not constitute an HCV 5 area as defined in the Toolkit, but it is no less important for meeting basic needs than areas identified as HCV 5 and must also be accommodated in

⁶ Tembawang is one among a number of local terms used by Dayak groups in western Borneo to describe valuable intensively managed agro-forests enriched by the planting of valuable fruit trees and other useful plant species that are typically established on or near old village sites and grave sites. In areas of long occupation, *tembawang* may make up a surprising large proportion of what are at first sight ‘natural forests’.

spatial planning by the MU.

The HCV toolkit takes into consideration that there are non-HCV 5 areas important to communities, but these areas are to be addressed with the principle of free, prior, informed consent (FPIC) contained within RSPO. This ensures that landowners or farmers involved retain the authority and responsibility over their own lands, but they also have been made aware of the long-term implications of oil palm development on their productive and/or fallow land.

3. Methods:

This investigation was carried out by an inter-disciplinary team drawn from four different institutions: the international human rights organisation, Forest Peoples Programme (Marcus Colchester and Patrick Anderson), the Indonesian palm oil monitoring NGO, SawitWatch (Norman Jiwan, a member of the Executive Board of the RSPO), the Indonesian NGO, HuMA, which specialises in legal and community rights (Andiko) and Wild Asia, a social enterprise advising businesses on natural resource management (Su Mei Toh).⁷

There was a discussion about whether or not the team should include company representatives to ensure a balanced assessment process. On the other hand, there was a concern that the investigation should maintain independence, transparency and avoid conflicts of interest.⁸ After discussions among all these parties, it was agreed that rather than join the team GAPKI and Wilmar International would advise and assist the investigation and would be provided with a chance to comment on the initial findings presented in the draft report before it was finalised. The team would however retain editorial control of the report and would make the findings public at the same time as submitting them to the RSPO Board.

The investigation was made in three parts: legal and documentary analysis, to establish the legal and procedural framework; field visits to areas exemplifying the problems and; interviews with communities, companies, NGOs and officials to get a range of perspectives and to seek recommendations for how to improve or remedy the situation.

Field visits were made to the following sites in West Kalimantan (Indonesian Borneo):

- PT IP in Landak district
- PT PP in Landak district
- PT Wilmar Sambas Plantation (in the process of being renamed PT PANP) in Sambas District

Interviews and groups discussions were undertaken with the following:

⁷ See Annex 2 for summary biographies of the team members

⁸ Independence of assessments and transparency of information are fundamental principles critical to the credibility of the RSPO process.

HCV and RSPO: results of an investigation

- Daemeter Consulting
- Wilmar International
- PT PP
- PT PI
- PT WSP (PT PANP)
- Sinar Mas
- GAPKI
- Gubernur of Kalimantan Barat
- Bupati of Landak
- Department Kehutanan
- BPN
- BAPPEDALDA
- WALHI KalBar
- WWF-Indonesia
- The Nature Conservancy

A preliminary draft of the report was circulated for comments to company interviewees on 17th October 2009. This report has taken into account all comments received by 23rd October 2009. This document is a public document and is being shared in order to facilitate a broader debate about how to secure the RSPO's objectives, especially in the context of Indonesia.

4. Findings:

4.1 The legal framework:⁹

As noted, the HCV approach has not yet become part of Indonesian law and remains a voluntary procedure adopted by companies operating within the framework of the Forest Stewardship Council and Roundtable on Sustainable Palm Oil's certification processes or other interests also adopting corporate 'best practice' procedures. This section (4.1) thus summarises the possible ways that relevant laws might be applied to strengthen the application of the HCV approach. The following sections (4.2 to 4.6) then examine the current situation whereby lands are in fact being reallocated without HCV being taken into account and without legal security to prevent their misuse.

4.1.1 Forest Status and Function

Forests in Indonesia are defined using natural and political approaches. In the natural approach, forests are defined as ecosystems dominated by trees in an allied environment. In the political sense, it is a forest area established by government to be maintained as a permanent forest. Under the political definition a forest can be an area without any trees and applies to large areas in the outer islands that are not gazette as national forests.

Law No. 41 of 1999 on Forestry (UUK) Article 5 establishes forests based on its status: a) state forest, and b) *hutan hak* or forests encumbered with rights. Despite the

⁹ For a much more detailed legal treatment in Bahasa Indonesia please see Annex 3.

category of *hutan hak*, forests under the management of customary communities are placed within the scope of state forests. Customary forests are state forests whose management is handed over to customary law communities. All forest areas are classified under function as either conservation, protection or production forest.

4.1.2 Forest areas for plantations

Government Regulation No. 26 of 2008 on National Spatial Planning classifies areas in the national spatial plan into ten categories of protected and cultivation areas with national strategic value (article 50). Oil palm plantation development falls under cultivation areas.

4.1.3. Legal Aspects of Plantation Establishment

Plantation lands can be divided into two types, namely state lands and lands controlled directly by communities. Forest areas are also divided into the categories of state forests, which are areas without any rights-holders, and *hutan hak*, or rights forests. These are non state forest areas encumbered with property and or usage rights.

State forest areas have the most potential to serve plantation development interests. Based on national spatial plans, certain state forest areas are allocated for agricultural plantation development. These areas are known as Conversion Production Forest. The criteria for areas designated to become Conversion Production Forest (HPK) include factors such as slope, soil type, rain intensity and ability to maintain its environmental functions and capacity. Other forest areas used for plantations are Areas for Other Uses (APL) or Non-Forestry Cultivation Areas (KBNK). These are state forests that are designated as non-forest areas by Forestry Ministerial Decree on Appointment of Forest Areas and Provincial Waters.

As well as fulfilling the requirements of regulations relating to capital investment, oil palm plantation companies in Indonesia have to go through four legal processes: 1) *Ijin Lokasi* (location permit), 2) plantation company permit, 3) forest area release process and 4) the *Hak Guna Usaha* (Business Utilisation Right) acquisition process. The flow chart on the following page illustrates the most important aspects of the four plantation investment processes.

PLANTATION LICENCING PROCESS IN INDONESIA

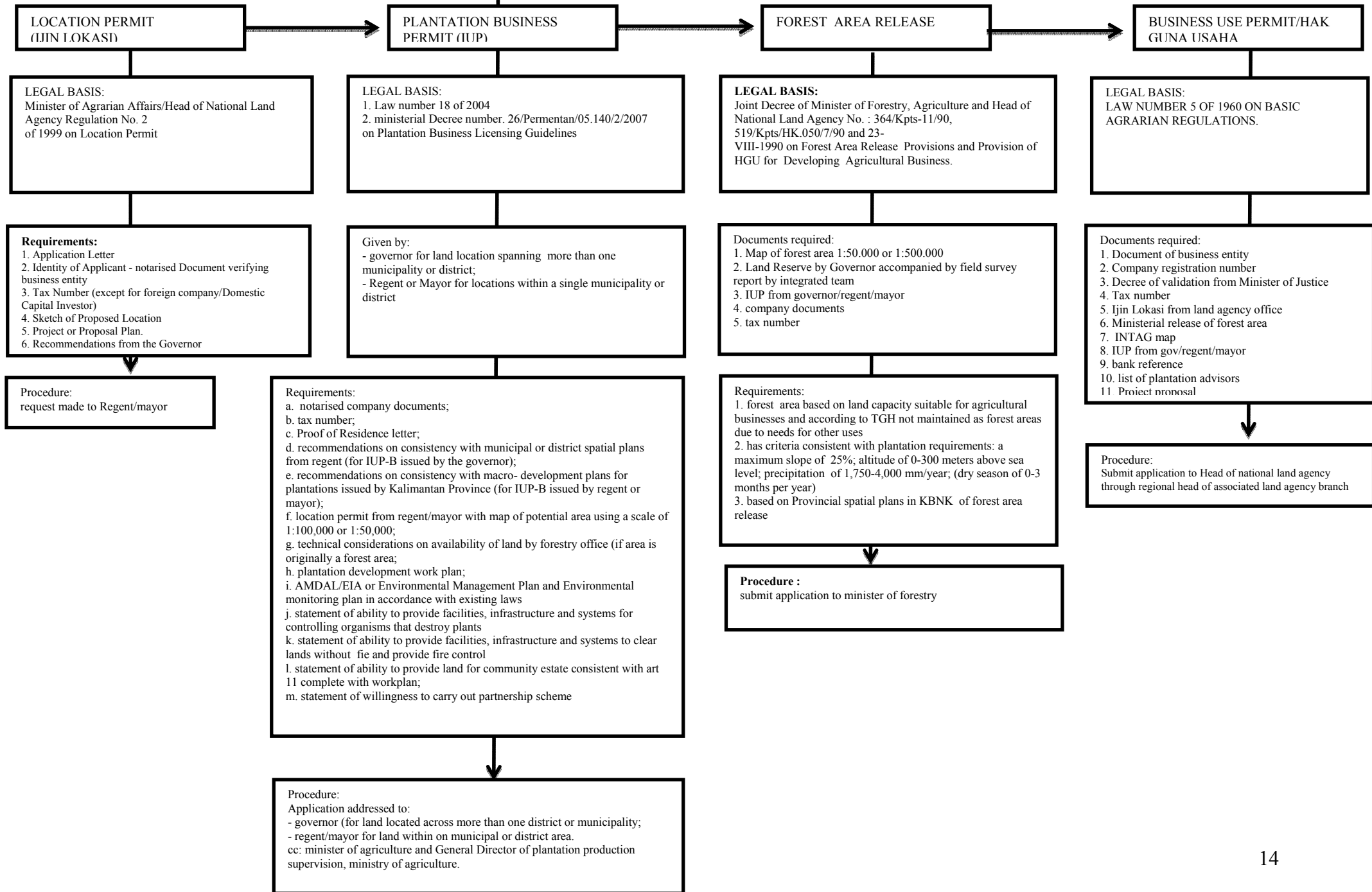

HCV and RSPO: results of an investigation

4.1.4 HCV in *Ijin Lokasi*

Sections AB V, article 8, paragraph (2) and paragraph (3) of the State Minister for Agrarian Affairs/National Land Agency Head Regulation No. 2 of 1999 on *Ijin Lokasi* determines that:

(2) prior to the land in question being freed by an *Ijin lokasi* holder, all rights or other interests already present are not reduced and are still recognized, including the right to obtain proof of ownership (title) by the right-holder and the authority to use and utilize his/her land for personal or business needs according to existing spatial plans, as well as the authority to transfer it to another party.

(3) The *Ijin Lokasi* holder is obliged to respect other parties' interests on land which have not been released, to not close or reduce accessibility for communities surrounding the location, and to maintain and protect public interests.

These two paragraphs could be used as a basis to protect HCV values 5 and 6 as long as the areas have rights or interests of other parties and community accessibility to it. HCV could be positioned in relation to this regulation as vital to local communities and public interests. These reasons for protecting HCV values, however, should not become an excuse for plantation companies to avoid obligations of managing and maintaining HCVs already identified in plantation plans.

4.1.5 HCV in plantation Environmental Impact Assessment (AMDAL)

AMDAL is an important part in the plantation permit process and includes the development of an Environmental Management Plan (UKL) and Environmental Monitoring procedure (UPL). Government Regulation No. 27 of 1999 on AMDAL determines that business ventures and/or activities which may cause significant and critical impacts on the environment are obliged to prepare an AMDAL. Those business activities and processes include:

1. changing land forms and landscapes;
2. exploiting renewable and non-renewable natural resources ;
3. wasting, pollute and damaging the environment, and eroding natural resources;
4. affecting the natural environment, artificial environments, as well as the cultural and social environment;
5. affecting natural resource conservation areas and/ or cultural heritage sites;
6. introducing plants, animals and micro-organisms;
7. the creation and use of bio and non-bio materials;
8. applying technology which may affect the environment significantly;
9. high risk activities and /or affect state land affairs

Environmental criteria for major and important impacts regarding a business and its activities include:

1. The number of people who will be affected;
2. The total area affected;
3. The intensity and duration of the impact(s);
4. The number of other environmental components affected;

HCV and RSPO: results of an investigation

5. Cumulative nature of impact(s);
6. Whether it is reversible or irreversible.

It is mandatory for companies that will have significant impacts to prepare an AMDAL. The method for compiling AMDAL is regulated in Environmental Ministerial Regulation No. 8 of 2006 on Reference AMDAL Guidelines, which require environmental components to be maintained and attention to be given to changes occurring in the environment. Conservation values have to be identified in the AMDAL document and conservation value management has to be incorporated into the Environmental Monitoring Document (RPL), which monitors environmental components that are significantly affected due to business and/or activity plans. These AMDAL requirements contain elements comparable but not identical to the HCV approach.

4.1.6 HCV in Releasing Forest Areas

A possible key to safeguarding HCV in the process of releasing forest areas from the national forest estate for use as agricultural plantations lies with the Considerations Team, which provides considerations and suggestions on whether or not to release certain forest areas. This team consists of the General Secretary, the Director General of Forest Businesses, the General Director of Forest Inventory and Utilisation and associated echelon 1 officials from the Ministry of Forestry.

Although the process to release forest areas to plantation companies mostly consists of administrative and technical considerations, the Considerations Team could tighten its standards for consideration through requiring the securing, safeguarding and management of High Conservation Values. However, after release approval is given to companies, the area falls under the supervision of local government.

4.1.7 HCV in HGU

In Governmental Regulation No. 40 of 1996, section 5 regulates the Rights and Obligations of HGU holders, and article 12 paragraph (1) d and e of section 5 stipulates that HGU holders are obliged to:

- a. build and maintain infrastructure and facilities in the HGU area;
- b. maintain soil fertility, prevent natural resource destruction and maintain environmental conservation according to existing laws;

These stipulations could be a basis for maintaining HCV in plantation areas, if high conservation value areas are regarded as areas needed to maintain environmental sustainability. In this case, if these obligations are not met by the HGU holder, then the HGU permit could be revoked.

4.1.8 HCV and Hutan Hak

Law Number 41 of 1999 introduces the concept of *Hutan Hak* (defined as 'forests with rights attached'). *Hutan Hak* are forests on land burdened with property or usage rights. Initially, *Hutan Hak* was part of what was regulated in Governmental Regulation No. 34 of 2002 which provided a legal basis for Forestry Ministerial

HCV and RSPO: results of an investigation

Regulation Number P.26/Menhut-II/2005 on Guidelines for Utilisation of *Hutan Hak*. Lands bearing titles or rights to land in the form of ownership titles, Business Use Rights and Usage Rights, can be established as *Hutan Hak* consistent with its function. This is based on District/Municipal Spatial Planning. Like State Forests, *Hutan Hak* has three functions, a) conservation b) protection and c) production, the criteria for which are established in National Spatial Plans. [1].

Thus far, forestry policies on *Hutan Hak* are still oriented towards timber, therefore, regulations on *Hutan Hak* are regulations on timber utilization, such as Forestry Ministerial Regulation Number P.51/Menhut-II/2006 on Letter of Origin (SKAU) for Transportation of Forest Produce Originating from *Hutan Hak*.

Forests containing HCV 5 or 6 located on HGU lands, if referencing the interpretation of *Hutan Hak* in Ministerial Regulation No P.26/Menhut-II/2005, could potentially be secured as *Hutan Hak*. However, HCV forest areas would need to be established by a decree from the local Regent/Mayor. We could not identify any case where this has actually occurred.

4.1.9 Rules for the revocation of *Izin Lokasi*

Location permits (*Izin Lokasi*) are regulated by the Minister for Agriculture in State Land Agency Regulation No. 2, 1999 concerning Location Permits. Location Permits are granted to companies to regulate how they acquire land for planned investments. It provides for a transfer of rights to use the land for the purpose of business investments.

The license period is based on the land areas required as follows:

1. Land areas of up to 25 ha are given a location permit for a duration of 1 year.
2. Land areas between 25 and 50 ha are given a location permit for 2 years.
3. Land areas over 50 ha are given location permits for 3 years.
4. If land acquisition has reached more than 50% of the area of the land designated in the location permit, then an extension may be granted for 1 year.
5. If land acquisition of at least 50% cannot be completed within the time, the land can be:
 - a) Used to implement the investment plan with an adjustment in the size of the area, with the stipulation that, if needed, it can be implemented so that the acquisition of land forms a unified area, or
 - b) Released to other companies or other qualified parties.

4.2 Reallocation of permits:

As noted, existing rules require licence holders to fulfil certain obligations within stipulated time periods in order to retain access to land. These rules, combined with the authority granted to district regents (*bupati*) under the autonomy laws introduced in 1999-2001, give them considerable discretionary powers to cancel permits and reallocate such lands to other parties.¹⁰

¹⁰ This discretionary power is also open to abuse.

HCV and RSPO: results of an investigation

Provincial and district authorities interviewed in this study emphasised that they are under an obligation to ensure that companies which are being granted permits actually do use the lands allocated to them for the purposes given. They note that they are required to do this in order to: comply with the law; secure revenues for their districts and; bring development to their constituents. During 2008-2009, there was a lot of criticism in the provincial press in West Kalimantan of the ‘hundreds’ of idle permits which were tying up lands and bringing no benefits to the province. Politicians and press opinion called for an end to this practice of tying up idle lands and urged companies to fulfil their development objectives as speedily as possible. At the same time, *bupati* were called on to reallocate lands to more active investors.

The investigation found that this reallocation has indeed been happening on a large scale in various parts of the province. In 2006, the Wilmar Group’s operations in West Kalimantan, for example, extended over a total area of 120,100 ha. in active *izin lokasi*. By 2009, *bupati* had cancelled permits to almost all these areas and had then restored to Wilmar only 52,204 ha, meaning they had lost nearly 68,000 ha. of lands. In the process 21,291 ha. of lands identified as HCV areas had been passed to other companies (see Table 1).

Table 1. Reallocation of Wilmar lands to 3rd parties

Companies	Old Izin		Revised Izin		Differences	
	Total Ha	HCV	Total Ha	HCV	Total Ha	HCV
PP	20,000	4,235	5,135	228	14,865	4,007
PI	20,000	7,304	6,498	1,195	13,502	6,108
IPM	18,000	5,811	8,441	1,695	9,559	4,116
APS	20,000	5,463	12,000	3,581	8,000	1,882
DLP	15,000	7,276	7,140	4,883	7,860	2,393
PANP (WSP)	14,100	1,653	3,100	1,083	11,000	570
BCP	13,000	2,671	9,890	457	3,110	2,214
Total	120,100	34,414	52,204	13,123	67,896	21,291

Source: Wilmar Group

The main beneficiary of this reallocation of land in Landak has been the Djarum Group which has secured a six month *izin perpanjangan*¹¹ to substantial areas previously allocated to Wilmar. Djarum is not a member of the RSPO and does not have a long track record in the palm oil sector.¹² The investigators recorded allegations from both company and community interviewees that Djarum was clearing lands in areas previously allocated to and surveyed by Wilmar. Allegedly, Djarum has been opening up these lands prior to securing an *izin lokasi*, prior to carrying out environmental impact assessments (AMDAL) and prior to securing agreements from

¹¹ The equivalent permit often issued with a duration of one year in other districts is known as *izin info lahan*.

¹² Djarum is the trade name of a very large Indonesian tobacco company. The Djarum group does have a long history of estate crop and smallholder development but has only recently diversified into palm oil.

HCV and RSPO: results of an investigation

host communities. In Sambas district, areas previously allocated to Wilmar have been allocated to another RSPO member company, Musim Mas.

The exact circumstances under which these permits have been suspended and reallocated has varied from case to case. In some cases the companies have received the requisite first, second and third written warnings that they must acquire or plant 51% of the lands in the *izin lokasi* within three, two or one month respectively or else their land will be forfeit. In some cases the companies have submitted applications for one-year extensions more than three months before the expiry of their *izin*. They have lost their permits nonetheless and been awarded reduced areas (not always of the areas they would choose) instead. Although in at least one case the *bupati* delayed responding to a timely application for renewal and just let the permit expire, the companies have chosen not to contest any of these decisions on the grounds that this would only worsen their relations with the local authorities.¹³

4.2.1 Why the delays?

As noted above, companies are issued *izin lokasi* for a period of three years during which time they have to: carry out initial surveys, socialisation programmes and environmental impact assessments; secure investments; apply for and be granted requisite permits for clearance and construction and; install the necessary infrastructure. With these in hand they can then acquire and clear lands and begin planting. They are then ready to apply for the thirty five year land use lease (*hak guna usaha*) on which they establish their core estate (*inti*) and also make arrangements for other areas to be developed as associated smallholder schemes (*plasma*). Given normal delays, transportation difficulties, financial challenges, recruitment procedures and the slow processes of securing permits, fitting all these actions into three years is quite onerous.

RSPO members have taken on additional commitments which also have to be fitted into the 3 year period before they begin land acquisition and clearance. These additional actions necessary to comply with the RSPO P&C include:

- *participatory* social and environmental impact assessments
- identification and mapping of customary rights areas
- participatory assessments to identify and develop management plans for, High Conservation Values
- negotiations with local communities and indigenous peoples to ensure no lands are taken over without the communities' 'free, prior and informed consent'
- in addition, as agreed, in July 2009, companies now have to comply with a 'new plantings' procedure, including posting summaries of their HCV assessments and FPIC procedures on the web for 30 days to ensure transparency and compliance with the P&C (see section 2.2 above).

In the specific case of Wilmar, in November 2007 the company decided to freeze all land developments in all its operations as a response to complaints filed by NGOs with the RSPO and the IFC alleging that the company was opening up lands without

¹³ The office for appeals against the decisions of *bupati* is the *Pengadilan Tata Usaha Negara*, PTUN, an administrative appeals body.

HCV and RSPO: results of an investigation

due legal permits and impact assessments and in violation of RSPO principles, with resulting land conflicts. This freeze was also required due to a decision of the Environment Ministry, while an investigation was undertaken into allegations that the Wilmar subsidiaries were using fire to clear lands. Wilmar agreed to improve its performance and accepted mediation by the IFC's Complaints Advisory Ombudsman to resolve land disputes between the company and communities in Sambas district. The company then contracted consultancies to carry out the HCV assessments of its *izin lokasi*, which slowly and methodically began their work. The net result was that the companies had not completed all required actions before their three year terms expired.

Our investigation also identified other reasons that Wilmar had found it hard to complete all the legally and voluntarily required activities prior to the expiry of their permits. In the early 2000s, the Wilmar Group, founded in 1991, was considerably expanded through a negotiated merger between Kuok Oil and Grains of Singapore, the PGEO Group and PPB Oil Palms of Indonesia. Just prior to the merger with Wilmar International, the Sitorus group actively and very rapidly increased the number of *izin lokasi* held by its subsidiary companies.¹⁴

This process of 'land-banking' remains quite common in the palm oil sector. Companies with large 'land banks' are attractive to investors and so can expand their operations and trade in palm oil and other oil palm products faster than smaller, more modest competitors.¹⁵ A downside however is that these business practices put a strain on management which struggles to bring all their new acquisitions into compliance with the law and management best practices. Wilmar staff interviewed in this study accepted that the rapid expansion of the group's holdings prior to the merger has contributed to delays in bringing their areas up to the RSPO standard.

4.2.2 Why the reallocations?

The district *bupati* in Landak and West Kalimantan Provincial *gubernur* interviewed during this investigation gave the following reasons for suspending companies' *izin lokasi* and re-allocating the lands to other parties:

- The permits had expired (*bupati* and *gubernur*)
- The companies had more land than they could manage (*bupati*)
- We cannot let land stand idle (*bupati* and *gubernur*)
- Land must be used for the prosperity of the people (*gubernur*)
- The companies agreed to reduced areas (*bupati*).

The *bupati* in Landak also clarified that local government officials lack training in RSPO procedures and HCV zoning and so lands may be reallocated without their

¹⁴ Jan Willem van Gelder, Hassel Kroes and Howard Law, 2009, *Wilmar International: a research paper prepared for the Palm Oil Monitoring Initiative (POMI)*, Profundo, Amsterdam pp. 2- 8. As a result of these and subsequent mergers and buy outs, Wilmar International is currently valued at almost US\$17.9 billion. The report cited provides much more details about the financial structure and ownership of Wilmar International.

¹⁵ In 2008, Wilmar's annual sales were reported to be valued at US\$ 29,145 million, yielding net profits of more than US\$1.5 billion (Ibid.).

HCV and RSPO: results of an investigation

value being known or appreciated. He noted that at present the spatial planning process does not include these criteria. The spatial planning procedure has not yet been completed in Landak in any case.

4.2.3 Community views about land reallocation:

Short but intense group discussions with community representatives were held in four villages to ascertain their views about the HCV process and the reallocation of lands to third parties. These were Rasan and Amang villages in Landak, where the majority of residents are Kanayatn Dayaks, and the Melayu settlements of Tempapan Hulu and Tempapan Kuala in Sambas district.

In all cases, the community representatives interviewed stated that they had not been consulted by government officials prior to the areas in Wilmar's *izin lokasi* being reallocated to other companies. In all four cases the view was strongly expressed that now that they had developed an understanding with Wilmar, had begun to receive benefits in terms of newly installed infrastructure and jobs and had entered into negotiations about compensation and smallholder allocations, they would prefer to have Wilmar stay on their lands than have to begin again with another company whose performance and track record were unknown to them.

4.2.4 Excising HCV areas when securing HGU:

The security of HCV areas under the permitting process is not only potentially jeopardised through the reallocation of *izin lokasi* by local authorities. It is also normal practice in Indonesia that companies, after they have completed their AMDALs and land acquisition processes, apply for HGU to reduced areas for planting as *inti* and *plasma* and relinquish wider areas that are not of interest to them. What happens to HCV areas in this process?

Company interviewees describe three possible outcomes for HCV areas as they move from holding *izin lokasi* to the definitive HGU.

- HCV areas are excised from concessions and handed back to the government
- HCV areas are excised from the concessions as they are considered to be community lands (areas important for HCV5 or HCV6 or lands that the community chooses not to have planted).
- HCV areas are incorporated ('enclaved') in the HGU and managed by the company.

The management and legal implications of these land allocations are summarised in the sections 4.4 – 4.8. There are however also strong financial incentives for companies to excise as much unproductive lands from their concessions as they can.

4.3 Financial incentives:

As explained by company interviewees and confirmed by government officials, it is advantageous for companies to excise HCV areas from their concessions. This is because:

HCV and RSPO: results of an investigation

- Managing and protecting HCV areas is costly. It may require: expensive and iterative consultations and negotiations with other stakeholders; employment of monitoring teams and forest guards to prevent illegal access and use; logistical costs of monitoring and enforcement and; regular review of remote sensing data as part of monitoring.
- Companies pay a significant land tax on their HGU. This is normally charged at a flat rate in accordance with the hectareage. Including substantial areas of unplanted lands within the lease thus affects profitability.
- Under Indonesian law, companies acquiring HGU for planting oil palm also have to establish a proportion of the land in their prior *ijin lokasi* as smallholdings. Normally this is in the proportion of 80 to 20, though in the case of Landak it is 70 to 30.¹⁶ Thus the larger the land area that is taken into HGU, the greater the area of smallholding that needs to be established.

Combined together these reasons provide a considerable incentive for companies to hand back to government lands that they consider unplanted.

4.4 Land acquisition: long term implications for communities

All of the three plantation areas visited during this study overlap the customary lands of local communities including various sub-groups of Kanayatn Dayaks in Landak and Melayu groups in Sambas. As noted in previous studies, despite constitutional and human rights provisions which recognise customary rights in land, most local communities and indigenous peoples in Indonesia lack secure land titles. When companies are allocated lands for plantations through spatial planning and then the allocation of permits, this is usually done by the government without any consultation with local communities. Companies are then expected to deal directly with the communities to acquire lands for their estates by negotiating with the local communities in cooperation with the land agency.¹⁷

During this investigation the community representatives interviewed separately and consistently noted that they had entered into negotiations over lands with Wilmar subsidiaries and had begun, or had already reached, agreements to relinquish lands to the companies for planting oil palms. Those that had already concluded these negotiations had received monies for relinquishing their lands and noted that they had agreed to the proposed land developments because they hoped this would improve their welfare, generate jobs and income, and allow them to acquire smallholdings. The villages in Landak also stressed the importance of company roads which now allowed them access to local towns, services and markets.

¹⁶ Landak District Regulation No. 10 of 2008 on Plantation Business Development (see Annex 4). This means that for every 70 hectares taken into HGU the company must arrange to plant 30 hectares on other parts of their *ijin lokasi* as smallholdings allocated to the local communities.

¹⁷ The details of this process have been explored in detail in a prior report: Marcus Colchester, Norman Jiwan, Andiko, Martua Sirait, Asep Yunan Firdaus, A. Surambo and Herbert Pane, 2006, *Promised Land: Palm Oil and Land Acquisition in Indonesia – Implications for Local Communities and Indigenous Peoples*. Forest Peoples Programme, Sawit Watch, HuMA and ICRAF, Bogor.

HCV and RSPO: results of an investigation

However, the investigation also noted that in all cases the community representatives were of the view that they were only temporarily relinquishing their lands to the companies for the duration of the lease (a HGU is initially granted for a period of 35 years). It was their expectation that the land would revert to the communities at the expiry of the lease. When it was pointed out that under Indonesian law lands in expired HGU revert to the State and not the communities, who are considered to have relinquished all rights in the initial land acquisition, community leaders were shocked. They vehemently asserted that the lands were theirs and should revert to them and that they had only lent the lands to the companies for their use (*hak pakai*). Two interviewees in the widely separated districts went on to state that they would never have agreed to release their lands if they had known that this was permanent. This suggests that community leaders had not received adequate information about the law prior to entering into negotiations and, contrary to RSPO standard, they have not freely consented to surrender their lands.¹⁸

The lack of land security for communities in all the project areas has major implications for the long term viability of HCVs.

4.5 HCV assessments:

Two consulting companies were contracted by Wilmar to carry out the HCV assessments. In Landak, they were undertaken by Daemeter Consulting from Bogor; while the concessions in Sambas were assessed by MEC (Malaysian Environmental Consultants) from Kuala Lumpur. Daemeter and MEC are both highly experienced consulting companies working in the region. Copies of the HCV assessment reports for Wilmar's Landak PT PI and PT PP were shared with the investigation team while the MEC's report on PT WSP for Sambas was not as the document had apparently not been finalised at time of the investigation.

As mentioned previously, the HCV assessments were belatedly carried out. Although Wilmar had procured *ijin lokasi* on their concessions since 2005/6 (which was during RSPO's two-year pilot implementation period), they did not undertake the required HCV assessments for new plantings (Criterion 7.3) until 2008, after the moratorium. When the assessments were finally carried out, parts of the concessions had already been cleared (more than 1,000 ha of forests in the case of PT PI, Landak). These areas were not included in the HCV assessments, as they would have to be excised from Wilmar's potentially certifiable areas, as per the interim RSPO guidelines on new plantings on HCV areas during the trial period.

However, these forest clearances do have implications for the remaining HCV areas identified, as it has significantly reduced forest areas that communities rely upon for basic needs. Daemeter's consultant agreed that villagers will be pushed to use the resources from remaining forest stands, regardless of whether these are HCV forests or not.

¹⁸ Forest Peoples Programme, 2008, *Free, Prior and Informed Consent and the Roundtable on Sustainable Palm Oil: a guide for companies*. Forest Peoples Programme, Moreton-in-Marsh.

HCV and RSPO: results of an investigation

4.5.1 The assessment process and participation of communities:

It is not the objective of this investigation to review the HCV assessments conducted, but as part of proceedings, the team invited feedback from the community interviewees regarding the process of HCV identification. In all cases, the village leaders understood and highly appreciated that the HCV process was undertaken. The process includes socialisation and community consultations also helped to build a working relationship and trust between the company and villagers.

However, in Amang the head of the village (*kepala desa*) expressed his unhappiness over the lack of participation and consultation and feedback process in his village, which he contended was insufficiently conducted. This was fed back to the consultant team involved. According to them, the entire process at Amang had been conducted according to protocol, and two different levels of consultations were initially held, as follows,

- An inter-village or *antar-desa* meeting with the attendance of between 15-30 hamlet representatives to socialise and plan subsequent field visits (where the kepala desa himself attended), and
- *Dusun*-level visits where the HCV identification was carried out with various community members, including the leaders, adat leaders, women, underprivileged members included.

Their records show over a hundred recorded interviewees for Desa Amang.

After the completion of fieldwork and data analyses, a public consultation session was held by the Daemeter team to feedback the results of the assessment to the communities, this was conducted at the *kecamatan* level. Although it wasn't held at individual *dusun*, the public consultation saw the involvement of the villagers from various *desa*. It also included representatives from local government.

It isn't possible to ascertain the precise issue or motive of contention with regards to Desa Amang as it is not the objective of this investigation, which was conducted over a very short timeframe. However, this appears to be an invaluable reminder that there can never be enough consultations in a participatory process, and also highlights the need for a robust communication and grievance procedure system to be in place. This is of great importance as oil palm development means irreplaceable conversion of forest areas, which is associated with potentially very serious social and environmental impacts. Hence there should be clear understanding and consensus between the company and major stakeholders, especially the affected local communities, that any development and management steps agreed upon would be suitable to maintain any critical values **prior** to any implementation.

Several points need to be noted with regards to the HCV assessments conducted:

- First, the assessments conducted at this stage only made **indicative identification of some HCVs** (i.e., not all HCV 5 and 6 were mapped in detail), as detailed participatory mapping of each *dusun* would require a large investment in time and resources to complete, which is not within the consultants' terms of work. According to Wilmar, it would take up to three years to map all *dusun* present in

HCV and RSPO: results of an investigation

their *ijin*. In view of this, the consultant company (Daemeter) conducted training for Wilmar staff in order that they will facilitate and lead this participatory process as an internal (company) project. The participatory mapping training session was conducted at a certain hamlet with the villagers, where detailed data on HCV 5 and 6 were identified and mapped. Unfortunately, according to Wilmar, this hamlet no longer remains within their *ijin lokasi*.

- The assessment that was conducted was HCV **identification** within Wilmar's *ijin lokasi*, the first step in the HCV process. This assessment was not meant to deliver specific management guidelines, or monitoring protocols for the Wilmar concessions. However, as per the Indonesian HCV toolkit, broad recommendations were made in the consultant's reports that are meant to provide the basis for further discussions with the Wilmar management team to develop detailed management plans. This has not yet occurred. Management options for HGU where it concerns HCV areas (e.g. whether to include or exclude them from HGU), according to the consultant, would be one of the topics for further discussion.

4.5.2 HCVs identified:

The Wilmar concession areas visited are located within human dominated landscapes. According to the reports available (only for the Landak concessions), remnant natural forests comprise a total of only ~600 ha and ~1,000 ha in PT PI and PT PP respectively (although in the former, ~1,000 ha of secondary and remnant natural forest had been cleared before the moratorium was implemented). Although limited, they are considered regionally important as endangered habitats (HCV 3); locally important for harbouring species of concern (HCV 1), as well as for local people in terms of provision of some basic needs (HCV 5). The protection of watersheds and riparian habitats (HCV 4) is critical for multiple values, especially HCV 5, but also to maintain connectivity of habitats for the conservation of species.

Among the HCVs identified are the following areas:

HCVs:	<i>Brief summary of HCVs found in PT PI and PT PP (Landak):</i>
HCV 1	Areas that contain important levels of biodiversity: <ul style="list-style-type: none"> ○ Remaining species of concern, due to restricted habitats remaining ○ Riparian habitats and existing corridors ○ Hutan lindung, hutan larangan, tembawang
HCV 2	Large landscapes and natural ecological dynamics: <ul style="list-style-type: none"> ○ Not present, landscape is human-dominated agricultural mosaic, with fragmented remnants of natural areas.
HCV 3	Rare or endangered ecosystems: <ul style="list-style-type: none"> ○ Includes all remnant forest fragments, will also affect other values, e.g. HCV1, 4, 5 and 6. <p><i>(But social, political, legal and ecological factors make this value a challenge to maintain.)</i></p>
HCV 4	Areas that provide important environmental services: <ul style="list-style-type: none"> ○ Riparian and erosion control ○ Provision of clean water and flood prevention ○ Control of erosion and sedimentation (~31% of area has very high or high erosion potential, especially the steep slopes from the edges of the

HCV and RSPO: results of an investigation

	sandstone cuesta)
HCV 5	Natural areas critical for meeting basic needs of local people: <ul style="list-style-type: none">○ Provision of some basic needs for local people, including clean water, building material, fuel, vitamins & minerals, and protein.
HCV 6	Areas critical for maintaining the cultural identity of local communities: <ul style="list-style-type: none">○ Sites of cultural importance, including sacred sites.

4.5.3 Maintenance of agricultural areas:

As mentioned previously, under the current HCV Toolkit, agricultural areas are not considered HCV 5, although they are recognised as ‘critical for the basic needs’ of local people. However, in line with the guidance in the toolkit, these areas, including individually owned rubber gardens, rice, or pepper fields, etc must also be identified and mapped to prevent conversion of these productive areas to oil palm (any development on these areas would require the free, prior informed consent of the landowner).

As it is usual for Dayak communities to practice shifting agricultural systems that incorporate fallow cycles to restore land fertility, the team was concerned that with the increasing pressure to develop oil palm on “idle” land, there might not be sufficient agricultural land for future use as village populations expand; or that fallow cycles, already on a downward trend, will continue to decline even further, affecting soil fertility and crop yields. This will affect future food and livelihood security, as well as increase the pressure to use HCV areas to fulfil basic livelihood needs, thus increasing the vulnerability of communities and their environments over the long term.

Interviews with community groups clearly indicate that they do not intend to surrender their productive agricultural land for oil palm – only land that is currently unproductive would be surrendered. But when further asked if they thought there would still be sufficient agricultural land in 5 or 10 years after surrendering their unproductive areas, no one could confidently respond.

The Indonesian HCV toolkit focuses its questions on how development would affect the basic needs of a community as met from forest and other natural areas, rather than how development would affect their needs from non-HCV, or agricultural, areas. Similarly, the HCV identification report does not address if there will be sufficient agricultural land to meet a community’s potential basic needs, although it does acknowledge that oil palm development should not impair their agricultural capacity.

As noted, under the current legal framework, once communities agree to surrender their unproductive land for oil palm, they effectively lose it in perpetuity. It is critical that discussions over lands that may include areas set aside for future use (whether held by community or individually), or is under a fallow cycle, are dealt with extremely carefully. The FPIC procedure needs to be rigorous.

4.5.4 What HCV 5 is not:

HCV 5 should not be mistaken as a tool for analysing community livelihoods for the goal of developing sustainable livelihoods, such as that of a sustainable livelihood framework (SLF) approach. While HCV 5 does take into account changes in the trends of natural resource use by communities, the SLF takes a more holistic and more detailed approach, analysing livelihood assets and strategies; markets, institutions and policies; analysed within a vulnerability context to develop sustainable livelihood outcomes. As the wording implies, **HCV 5 merely identifies and aims to maintain and enhance those natural areas where local people derive their basic needs, where those needs cannot be easily met by alternatives.**

Where alternatives become available and accessible for every strata of community (e.g., affordable store bought food, building materials), and the natural area stops being the primary resource for basic needs, that an area may even lose its HCV 5 status. **(The toolkit carefully states that even if only one family in a village depends on a natural area for basic need, that area must be considered HCV 5).**

The use natural areas to generate commercial income beyond the requirement for “basic needs” is also not considered HCV 5. The HVC toolkit also does not consider the wider impacts of cultural, social and economic changes that come from an increasingly dominant cash economy as rural populations shift away from a subsistence livelihood. These considerations are better discussed in a separate but complementary framework, e.g. social impact assessment (Criterion 6.1 in RSPO P&C), which should incorporate elements of a SLF approach.¹⁹ The SIA, HCV and FPIC concepts and processes must be approached hand-in-hand, as they are directly complementary to one another.

4.6 Management options:

This section further explores the three management options described in 4.3: excision to state land; excision to communities (also called ‘enclaving’²⁰); and incorporating unplanted areas within HGU.

Although management options have yet to be fully developed for the areas visited by the investigation team, discussions with the Wilmar management team indicated that they had started to deliberate on several options for specified areas. These include examples of excision to state land and incorporation into HGU, as follows:

- Large riparian buffers (Landak): Although the riparian buffers of large rivers (>30m) fall within the company’s *ijin lokasi*, these areas are designated under Indonesian law as “Local Protection Areas”. The company will not apply for

¹⁹ Scoones, I., 1998, *Sustainable Rural Livelihoods: A Framework for Analysis*, IDS Working Paper 72, Institute of Development Studies, University of Sussex

²⁰ The term “enclaving” in this context simply means areas that are unplanted, usually used in association with community land. It does not denote the status of the land, as it can either be included or excluded from a company’s HGU. Usually, it is excluded. For sake of clarity, the term is not used in this report.

HCV and RSPO: results of an investigation

HGU over these areas. However, the investigation team was told that permits for these areas might be offered for other companies or individuals if Wilmar excises it from their management area.

- Community forest enhancement (Landak): The most developed option was with regards management of community forest areas (*tembawang*). This included a forest enhancement project with Illipe nuts (*tengkawang*, *Shorea* sp.), which they have secured a partnership with Aidenviroment. This project will also be supported by a Wilmar subsidiary PT Cahaya Kalbar, which owns a processing facility for the nuts. According to Wilmar, communities involved had agreed to the project, which would include keeping these HCV areas within Wilmar's HGUs. However, at time of the team's visit, the project was uncertain as the majority of the *tembawang* areas targeted for the project are now fall within Djarum's *ijin*.

4.6.1 Excision (HCV areas revert to the State):

Although simply excising HCV areas from their management area (HGU) will allow companies to avoid non-compliance with RSPO standards (i.e., no new plantings on areas of high conservation value), this does not give any assurance that the remaining HCV areas excised from their HGUs will be maintained, or will not be offered to other companies for development or be open to unregulated use by other parties.

There is no assurance under current local administrative structures that HCVs **outside** of company HGUs will be managed and maintained. The *bupati* interviewed expressed pessimism that HCVs could be effectively maintained outside of instruments such as RSPO requirements, as local government lack the enforcement capacity to monitor and manage HCVs. **The lack of clear laws and legal authority also hinders the ability of local government to dispense penalties to companies that develop on HCV areas.** Legal guidelines and authority, once developed, would have to be fully integrated between local and national authorities.

With regards to the future implication of the HCVs that have already been identified by Wilmar but that now lie within Djarum's permit, the *bupati* would only comment that the onus is fully on Djarum to be committed to maintain the HCVs. Although technically, this isn't an example of excision of HCV areas to state authority, it is worth bearing in mind that this is what could happen to any areas that are not included in a company's HGU. **Djarum is not a member of the RSPO and has no legal or voluntary obligations to maintain HCVs.**

4.6.2 Incorporating unplanted HCV areas within HGUs:

The lack of protection over excised HCV areas is acknowledged by the HCV consultants in their reports, who recommend that to adhere to the spirit and intention of RSPO, the best approach is a "collaborative arrangement between the company, local people, local government and NGOs".

This may require that companies **retain management authority** over HCV areas. For remnant forests, both large and small, the consultants recommend that the company acquire these HCV areas within the HGU as conservation set-asides (according to proper FPIC procedures, and with due compensation to land owners). For larger areas,

HCV and RSPO: results of an investigation

the recommendations are that these would be subject to collaborative and adaptive management plans, with elements including engagement of an NGO to facilitate development of a multi-stakeholder dialogue with local communities, community organisations and government, and to develop and implement a collaborative action plan.

Incorporating unplanted areas within a company's HGU adds a different set of pressures and responsibilities on a plantation company. However, setting aside forest areas within a plantation's management area for conservation of endangered species (HCV 1) is not without precedent. This has occurred in Sabah, Malaysia where the Wilmar's Sabahmas plantation forged a partnership with a conservation NGO and the Sabah Forestry Department to develop conservation initiatives for set-aside areas within its boundaries. Another possible example is in Kotawaringin Timur in Central Kalimantan, where Wilmar is seeking to negotiate an MOU with a conservation NGO to maintain an area of over 3,000 ha within its HGU as a conservation site. In this case, it is reported that the local *bupati* has agreed in principle to a lower land tax for areas within the HGU set aside for conservation purposes.

While the company has demonstrated commitment to set aside HCV areas for conservation purposes, it is not without resisting pressure from local government to convert it to productive use. Although there have been no cases reported as yet, legally there are no provisions to prevent local authorities from withdrawing a company's HGU if they fail to develop a minimum area, or convert it within a certain period. Land allocated for development is a major source of revenue that local governments would tend to want to maximise, hence any "idle land" would be seen as potential untapped revenue to be realised when offered to another company.

4.6.3 Excision (HCV areas revert to community):

The third management option, i.e. the excision of HCVs to be returned to community management, requires that local people have good comprehension of the objectives of HCV planning to ensure that the HCVs are maintained or enhanced. This requires sustained dialogue and communication between the company and communities. Although HCV areas outside of HGU are technically outside of a company's responsibility, neither the community nor the company work in isolation of each other, as the activities of one will affect the other.

Community resource and land use in the villages visited, to an extent, are still regulated by *adat*, or customary law, which may ensure that areas categorised as HCVs such as *tembawang*, sacred sites, as well as rubber gardens will be maintained. However, it is unrealistic to assume that this will be maintained in the long term, as expanding plantations, modernisation and cash economy starts to take a stronger hold in rural areas, without some form of reinforcement for the communities. Where the HCVs present are also critical for ecosystem health and basic needs (e.g. watershed areas, steep areas etc), all parties will need to work together to maintain these systems.

There is also concern that if left with insufficient land and resources once oil palms are established, communities will not be able to sustain themselves in future with the

HCV and RSPO: results of an investigation

remaining land, and will eventually be squeezed to utilise HCV areas as a last resort, to meet their basic needs (e.g., cleared for agriculture or extracted unsustainably).

An underlying problem with excisions from *Ijin Lokasi* to community is that such lands are not legally secure, because communities are not offered title to customary lands, whether held individually or collectively. This means that excised lands handed back to the community and not included in HGU could end up being allocated to another company by the *bupati*.

The other option is that social HCVs also be included in a company's HGU. This may allow for better awareness, collaboration and management of HCVs to occur in some cases (e.g. the company develops participatory community projects on community forests with the aim of increasing productive income of villagers), but major challenges remain. However, under strict application of the Basic Agrarian Law, these highly valued areas will eventually revert to the state upon completion of HGU period. Although there are yet no examples of this occurring (as HGUs are usually extended for another cycle by companies rather than ended), the lack of legal recognition for a customary community's right to their lands is the ultimate ticking timebomb, both for communities and HCVs.

4.6.4 Summing up management options:

The areas visited are human-dominated landscapes where natural forest areas are now in decline, due to the spread of agriculture and rubber smallholdings. With the rapid roll out of oil plantations in the province, encouraged by local authorities, remaining HCV areas are under increasing risk of being developed – by companies and communities alike:

- Companies, especially non-RSPO ones, who are under no current legal or voluntary obligation to identify or maintain HCVs;
- Local government are also under no current obligation to identify and protect HCVs before handing out permits for development;
- Communities, whose land and forests (for dwelling, food, building materials, income, customary uses) are increasingly “boxed in” by expanding plantations, may have no choice but to utilise HCV areas to expand their fields, or use resources unsustainably.

The importance and requirements of HCV identification, and subsequent management actions should be open for consultation and engagement with a wide audience, and especially local governments who are the ultimate decision-makers on land use. Unless there is clear guidance and support for how HCV areas should be dealt with at the local government level, there will continue to be inconsistencies in the outcome of HCV processes carried out with good intentions. Outcomes would be unpredictable and would differ depending on perceptions of local administrations toward conservation goals and local community concerns.

Ideally, HCV should be used as a strategic land-use planning tool, where critical areas for HCV are identified and managed within prescribed, allowable development. In which case, the National Land Agency (BPN) should be involved in HCV planning as they are tasked with overseeing land surveys, mapping and land administration on

HCV and RSPO: results of an investigation

national, regional and sectoral levels. It is BPN's role to inform local governments on areas to be allocated as *ijin lokasi*. The local governments currently lack the expertise, management capacity, and funding to be able to carry these out themselves.

Without clear ownership and support of the HCV process as a land-use decision-making tool amongst different state and national agencies, its application by well-intentioned companies abiding by a voluntary standard may not achieve significant progress on conservation or social objectives.

This investigation illustrates the well-known fact that the HCV concept by itself is not an assurance that valuable ecosystems will be conserved. If HCV areas revert to the state, decisions on how to manage HCVs are most often reduced to priorities other than conservation or social well-being, be it fiscal or political. Similarly, how and if communities manage HCV areas on their own lands will also be dependent on their current and future needs and desires. The HCV process *per se* is intended to only inform the planning process, and thus should be seen as just the starting point from which collaborative, participatory dialogues and action plans stem.

5. Conclusions and Recommendations:

The RSPO procedure seeks to encourage voluntary efforts by companies to identify and avoid clearing areas of high conservation value. Companies are also expected to manage their plantations so that these high conservation values are maintained or enhanced. The overall aim is to deflect palm oil expansion from valuable areas.

Based on the evidence presented above, the main conclusions of this study are the following:

- *HCV areas once identified are not being protected but are being re-allocated to other companies:*

Some RSPO member companies have invested a considerable amount of resources, time and effort in identifying High Conservation Value (HCV) areas and areas important for local livelihoods. These efforts have delayed land acquisition, clearance and planting. These delays have meant that companies have exceeded the permitted three-year period for preparing their areas prior to securing their final leases. Local government officials have chosen to terminate these permits, restrict the areas permitted to these companies and have re-allocated parts of these areas to other companies including non-RSPO members, some of which are allegedly clearing lands including HCV areas.

Although some of the delays have arisen from the novelty of RSPO procedures and the need to build up capacity in both consultancies and management, it is likely that similar situations will arise in future.

- *HCV areas are being relinquished by companies*

The study also found that RSPO member companies are choosing to relinquish substantial HCV areas identified in their initial permitted areas and are handing them

HCV and RSPO: results of an investigation

back to the government. They are doing this to avoid burdensome taxation, to reduce the size of the corresponding areas they are obliged to develop as smallholdings and to make it easier to comply with the RSPO requirement to manage HCV areas that are within their permits. However, HCV areas so released by the companies can be reallocated to other companies, which may not be RSPO members and which have no obligation to maintain or enhance HCVs.

- *HCV areas are not legally secure*

Indonesian law makes no explicit provision to protect HCVs although the study identified a number of laws and regulations which could *potentially* be used to strengthen HCV protection. However, **the laws as currently applied do not secure HCV areas**. When companies hand back HCV areas identified in their *izin lokasi* to the government, such areas are not thereby accorded any legal protection and can be allocated to third parties. Areas which the companies identify as under community ownership, or which are essential or critical to local livelihoods (HCV 5) and critical to cultural identity (HCV 6), are considered community lands. These areas may also not be included in final company leaseholds (HGU). Because community lands are not secured by law, these HCV areas are also vulnerable to reallocation to third parties. When HCV areas are retained within HGUs but are not planted, they may be secure for the duration of the permit (mean of 30 years, subject to renewal), but at the expiry of the lease these areas revert to the State, are not automatically accorded any legal protection and are then available to be allocated to other companies again. Areas of importance to communities, including HCVs 5 and 6, that were retained in HGU revert to the State and not the community at the expiry of the lease and are also not secure.

In sum, the intended result, that the application of the RSPO standard will secure HCV areas, is being frustrated by the ill-fit between the RSPO process and the policies, laws, regulations and procedures of the Indonesian government.

5.1 Recommendations:

A number of actions can be taken by a variety of parties to help close the gap between the RSPO's intended approach and the current reality which is failing to secure HCVs. The recommendations set out below derive in large part from interviewees' suggestions as well as from the legal analysis undertaken as part of this investigation.

While we consider concerted action to be urgently necessary to remedy the problems that have been identified, we offer these recommendations in the spirit of encouraging further discussion and not as prescriptions for reform.

Build up government comprehension and capacity:

- Government officials interviewed stressed that they and their staff need information and training in how to support and accommodate the RSPO approach. This training should extend from the level of central ministries, through the provincial and district authorities down to the village level.

HCV and RSPO: results of an investigation

- Planning agencies in particular need guidance on how to incorporate HCV zoning and consideration of community land rights into land use and economic planning processes.
- Officials noted that the incorporation of HCV zoning and land rights recognition into district level procedures will require additional staff and therefore increased budgets.
- Officials also recommended that NGOs need greater training and awareness about the RSPO and HCVs so they can help with implementation and ensure effective communications between communities and local authorities.
- The capacity of the national land bureaux (BPN) at the district level to recognise and title customary lands must be strengthened and resourced.

Legal Reforms:

- Amend the Environment Law to provide explicit requirements to protect HCV areas.
- Revise the implementing regulations and corresponding procedures for the recognition of customary rights under the Basic Agrarian Law so that they can be implemented at provincial and *kabupaten* level;
- New laws are also necessary to recognise and secure customary rights in line with Indonesia's obligations under the international human rights laws.²¹ This will require the collaboration of the national legislature. In the meantime clearer guidance needs to be given to local authorities of interim options to secure customary rights.
- Secure specific HCV and community areas at the local level by issuing local legislative acts, local ordinances or decrees.
- Amend the Plantations Act or other suitable laws so that on the expiry of a HGU lands can revert to community ownership and control and do not automatically revert to the State.

Procedural reforms:

- Spatial planning procedures should be amended to include zoning for HCV areas and to identify customary lands. Such areas should be excluded from palm oil development zones.
- Ensure that communities are consulted and informed by local government prior to permits being issued that extend over customary lands
- Allow for the extension of *izin lokasi* to 5 years (Permentan 26/2007) or provide clearer terms for their extension, where good faith behaviour can be demonstrated and subject to local community agreement.
- Revise AMDAL procedures to require the identification, maintenance and management of HCVs.
- Develop procedures by which regents could opt to return identified HCV areas to the authority of the Department of Forestry. This would then require the

²¹ http://www.forestpeoples.org/documents/law_hr/cerd_indonesia_urgent_action_jul09_eng.pdf

HCV and RSPO: results of an investigation

reclassification of released lands as ‘forests’ - specifically as ‘*hutan hak*’, for community areas, or as ‘*hutan lindung*’, for conservation as protected forests.

- Impose lower tax requirements on areas retained within HGU as HCV set asides.
- Improve transparency in the whole land use planning and land allocation process to encourage community and other stakeholder engagement and curb opportunities for corruption

Strengthen the RSPO’s capacity to address these concerns and the RSPO’s Generic Standard and National Interpretations:

- Task the most relevant RSPO sub-committee(s) or working group(s) with a suitable multi-stakeholder composition to deliberate these recommendations, suggest ways forward and assess how widespread these legal and procedural obstacles to compliance with the RSPO P&C are, not just in Indonesia but also in other palm oil producer countries. This group should also consider:
 - How to ensure greater transparency and improved communication between companies, communities and local authorities to ensure HCVs and community rights and interests are protected and managed during the permitting process and thereafter.
 - How to mobilise resources and initiatives to achieve these ends.
 - With the involvement of the RSPO national office in Indonesia, building up an accessible national database to pool information about HCVs.
 - Promoting a communications network that shares knowledge and ‘best practice’ lessons among RSPO members and ensures these lessons are shared with local and national authorities, NGOs and communities.
- Review and clarify the Guidance and Indicators in the RSPO’s ‘Principles and Criteria’ so that the requirements provide clearer indications on what companies need to do to ensure that HCVs are identified, secured and managed.
- Review and amend the Indonesian National Interpretation in order to:
 - Decide on workable but credible measures to compensate for HCV areas cleared between November 2005 and November 2007.
 - Upgrade the indicators and guidance to ensure that the RSPO C&I are achievable within the current legal and procedural context and suggest legal and procedural reforms to secure HCVs more effectively in the future.
 - Clarify that Free, Prior and Informed Consent procedures require that communities are properly informed of the legal consequences of ‘surrendering land’ to HGU (ie that on expiry of the lease the lands revert to the State and not the community).
 - Ensure that HGU leaseholds and replanting cycles are synchronised so that lands can revert to communities if they decide not to accept replanting on their lands.²²

²² Currently replanting occurs on average after 25 years but HGU are offered for 30-35 years. In effect therefore, at present, communities do not have the choice on whether or not to renew a HGU when they are being asked to decide on whether or not they wish to allow a second planting on their lands. In effect therefore even if a community opts not to have replanting after 25 years, they can’t get their lands back, as the lands will remain in the company’s leasehold for a further 5-10 years.

Review and clarify the HCV Tool Kit for Indonesia:

- Review and clarify the guidance given for the development of management plans for identified HCVs.
- Review and revise the guidance given for identifying and protecting HCV 5 including reconsidering whether or not HCV areas may include ‘non-natural areas’ that are critical to livelihoods and taking steps to ensure communities have adequate lands to maintain viable livelihoods given population increases and increased access to markets, while taking into consideration that the management of these areas should be retained by the original landowners and not transferred to other parties.

Final comment:

Widespread, effective and equitable compliance with the RSPO standard depends on good governance, transparency, accountability, rule of law and access to justice. If land allocations are made in ways contrary to these principles, there are bound to be serious obstacles to the RSPO approach – not just with respect to High Conservation Values. It is, however, beyond the terms of reference of this investigation to address these wider but crucial issues.

Annexes:

Annex 1. Terms of reference

The terms of reference reproduced below were those developed and agreed prior to the investigation. As noted in parentheses and in red some of the preliminary information is not correct.

A. TORs:

Situation:

Recent reports from the field suggest that efforts to get high conservation value areas set aside from conversion to oil palm in line with the requirements of the Roundtable on Sustainable Palm Oil are backfiring. According to this preliminary information, which needs to be verified in detail, already in three districts in Kalimantan, Indonesia, the district heads (*bupati*) have taken lands out of company concessions, being areas that the companies have set aside as HCV for social and environmental purposes. The *bupati* have then handed these same HCV areas over to other companies who are willing to chop the trees down and plant oil palm. The net result is that not only are HCV areas not being conserved but they end up being controlled by less scrupulous companies.

Specifically it is *alleged* that 2/3 of PT Wilmar Sambas Plantation concession in Sambas District, West Kalimantan, was excised from the company's concession and handed over to Duta Palma (Note: the field investigation showed it was Musim Mas not Duta Palma that has acquired lands previously held by PT WSP). In Landak District, some 8000 ha. of lands set aside as HCV have been handed over to the Djarum group (the areas acquired by Djarum are actually greater than this) and in Seruyan District, in Central Kalimantan, a few thousand ha. were reallocated to the Sampoerna group (this information has not been verified and seems to be erroneous).

According to the RSPO standard, for companies establishing new plantings to get certified as producers of 'sustainable palm oil', they must first identify and set aside primary forests and areas of 'high conservation value' and only then develop the remaining areas with oil palm (in accordance with the other P&C). The problem seems to be that, in Indonesia, under the terms of their licences (HGU) and in accordance with Indonesian law, companies have to clear lands allocated to them in their concessions in order to maintain their leasehold rights to them (the studies showed that the legal situation is more complex than this). The authorities, who are not party to the RSPO's voluntary standards, feel perfectly entitled to excise unused lands from HGU, when RSPO companies decline to convert them because they are HCV, and they then hand them over to other parties.

Activities:

The team will investigate the factual basis for these *allegations*. We will

- carry out a field visit to at least two sites (in West Kalimantan)
- seek to get corresponding information from other parties in other provinces reporting similar experiences (Seruyan and Sanggau and others if relevant)

HCV and RSPO: results of an investigation

- interview all affected parties including communities, companies, HCV consultants, government officials.
- document and analyse the relevant laws
- develop recommended actions for RSPO in order to prevent future occurrences of any problems identified
- report on our findings before RT7

Outputs:

Report on the findings.

Dates:

9-18 September: legal review and interviews with national agencies

23rd September: team meets in Pontianak

24-29 September: field investigation and interviews

15th October: draft report for comments to interviewees

25th October: report submitted to RSPO (and for public)

Composition of team:

Social specialists (FPP): Marcus Colchester and Patrick Anderson

Oil Palm specialist (SW): Norman Jiwan

Lawyer (HuMA): Andiko

HCV specialist (Wild Asia): SuMei Toh

Interviewees (preliminary list):

Local communities in Landak and Sambas

Wilmar

Daemeter Consulting

CBs

Bupati

Dep. Hut.

BAPPEDALDA

BPN

Dinas Perkebunan

GAPKI

Duta Palma

Djarum

Sampoerna

Funding:

Funds are to be made available for this research by the collaborating organisations from their own programme budgets. Suggestions of an external funder would be welcome.

B. Questions sent to GAPKI in advance of meeting:

Laws and Procedures

1. Do you think there are legal or procedural loopholes which allow the re-allocation of areas set aside as HCV to third parties?
2. If so what should be done to close these loopholes?

HCV and RSPO: results of an investigation

RSPO process

3. Is the RSPO NI for Indonesia clear enough (or does it offer enough guidance) to prevent or minimise the reallocation of HCV areas to third parties?
4. If not what can be done to improve them?

GAPKI's position

5. Are the problems that we think we have identified (but which we will be verifying in the following weeks) of concern to GAPKI ? (Do you know of other such cases?)
6. If so what does GAPKI think is the best way to address them?

C. Questions to Guide Investigation:

General legal questions:

1. What are the **terms relating to land use** under which licenses are handed over to companies to plant oil palm? (do companies have to clear the lands for oil palm within a certain period?)

- ijin prinsip
- IUP
- ijin lokasi
- HGU

2. What provisions in the law, if any, allow a company to set aside lands for environmental or social purposes (ie in line with HCV or FPIC) within a licensed area?

3. What authority do local government / *bupati* have to take lands back from licenses if companies set (parts of) licensed areas aside for social or environmental reasons?

4. Are there means by which companies can regularise lands set aside for HCV or as community areas, so they are secured from being licensed to third parties?

5. Are there means by which companies can contest the reallocation of lands set aside for HCV or community use?

6. What amendments in the laws and regulations would be necessary to ensure that lands set aside from HGU or *ijin lokasi* , for management as HCV or as community lands, were secured from being licensed to third parties?

Specific legal questions:

In the case of the PT Wilmas Sambas Plantations and the Wilmar subsidiary companies in Landak and Seruyan (and Sanggau? and others as identified in future)

7. What measures were undertaken by the companies to secure areas set aside from community use and HCV from being allocated to third parties?

8. Did the companies use all legal options to secure these areas from being reallocated to third parties?

HCV and RSPO: results of an investigation

Other technical questions:

9. What provisions were made in the companies' HCV management plans to ensure that HCVs were maintained or enhanced?
10. Were these plans shared with the communities, local authorities and bupati?
11. Did communities approve the extent of the areas set aside for HCV and for community use?
12. Did the companies discuss the need to secure areas as HCV and for community use with the local bupati or other authorities? Did they get agreement from the authorities?
13. What steps did the companies take to prevent HCV / community use areas being allocated to third parties? Did they take the issue up with the local authorities?
14. What commercial or financial connections are there between the companies that 'lost' their HCV / community use areas and the companies that have taken over these areas?

Community viewpoints:

15. Were the communities consulted by the company in HCV / community use plans?
16. Did the communities agree to the zoning and the associated management plans?
17. Were they consulted by anybody about the reallocation of these areas to third parties?
18. What negotiations took place in the relocation of these lands to the new companies?
19. What commercial or financial connections are there between the communities and the companies that have taken over these areas previously set aside for HCV/ community use?
20. What should the RSPO do to ensure that the RSPO P&C and country's legal frameworks are made compatible?

Company and CB viewpoints:

21. What are the key elements in an HCV management plan that companies should put in place to ensure compliance with the RSPO P&C? (and HCVRN tool kit?)
22. Who should be consulted and approve the zoning and management plans in a company HCV plan? Communities? Government?

HCV and RSPO: results of an investigation

23. Do/ should companies share their HCV zoning and management plan with communities and the government?
24. Can companies get certified if (some of) the area they set aside for HCV then gets destroyed by another operator? Or does this show that the companies' management plans were not viable / realistic?
25. Do companies feel that the RSPO HCV procedure needs to be changed in the light of experience?
26. What legal changes would be most necessary to ensure that HCV and community use areas are secured?
27. What should the RSPO do to ensure that the RSPO P&C and country's legal frameworks are made compatible?

Government viewpoints:

28. Are they aware of the RSPO? Do they know what HCV is? Do they understand that in line with the RSPO standard the companies are seeking to set aside lands for community use and to maintain and enhance HCV?
29. How does the RSPO approach fit with spatial planning processes at the provincial and district level?
30. Do they feel obliged to excise areas from companies licenses if areas are set aside for HCV or community use?
31. Can measures be taken locally, in conformity with the law, to secure areas from being allocated to other companies?
32. If not, what legal changes would be most necessary to ensure that HCV and community use areas are secured?
33. What should the government/ legislature / RSPO do to ensure that the RSPO P&C and country's legal frameworks are made compatible?

Annex 2. Composition of the research team

Marcus Colchester is English. He has degrees in Zoology and Ethnology and a doctorate in Social Anthropology from the University of Oxford. He is currently Director of the Forest Peoples Programme and Co-Chairman of the High Conservation Value Resource Network. He is also a member of Steering Group of The Forests Dialogue, Secretary of the Board of the Rights and Resources Initiative and a Fellow of the Samdhana Institute. He lives in England. He has been a member of a number of the RSPO's standard-setting committees and is Co-Leader of the RSPO's Task Force on Smallholders.

Patrick Anderson is Australian. He was a founder member of both the Rainforest Information Centre, Lismore, and the World Rainforest Movement. He developed and coordinated the forest campaign for Greenpeace International 1990-1999. He has lived in Indonesia since 2001, and worked for five years as Campaigns Advisor to the Indonesian Environment Forum (WALHI). He is a Trustee of the Grassroots Foundation, Germany, and activity leader on REDD Preparedness at the Samdhana Institute, Indonesia. He is currently Policy Advisor at the Forest Peoples Programme.

Norman Jiwan is Indonesian and a Kerambai Dayak from West Kalimantan. He has a degree in English from the University of Tanjung Pura, Pontianak. For two years he worked for the Indonesian Environment Forum in West Kalimantan (WALHI - KalBar). He is currently Head of Division for Social and Environmental Risk Mitigation at the Indonesian NGO, SawitWatch. He is a member of the Board of the RSPO and has served on a number of RSPO standard-setting committees, as well as acting as Co-Leader of the RSPO's Task Force on Smallholders.

Andiko SH is Indonesian and Minangkabau from West Sumatra. He has a degree in law from the University of Andalas, Padang, and is a program coordinator at HuMa. HuMa focuses on natural resource issues from the point of view of indigenous peoples, and provides analysis and support to NGOs and communities in order to promote just and environmentally sustainable legal reform in Indonesia.

Sumei Toh is a Malaysian. She has a degree in Biology and a Masters in Environment and Development from the University of East Anglia. She is currently an advisor of Wild Asia, a social enterprise based in Kuala Lumpur working to promote responsible practices in the natural resources sector. Her work focuses on the social aspects of natural resource management, especially in the forestry, plantation and tourism industries. Wild Asia has been involved with the RSPO process since its inception and continues to work to support companies in integrating good practice standards, and in improving systems to address sustainability challenges within industry.

Annex 3. Legal Review

Status Hukum HCV

1. Status Dan Fungsi Hutan

Hutan di Indonesia didefinisikan dalam pendekatan natural dan politik. Dalam pendekatan natural hutan diartikan sebagai suatu kesatuan ekosistem berupa hamparan lahan berisi sumber daya alam hayati yang didominasi pepohonan dalam persekutuan alam lingkungannya, yang satu dengan lainnya tidak dapat dipisahkan. Dalam pengertian politik hutan diartikan dalam lingkup kawasan hutan yang merupakan wilayah tertentu yang ditunjuk dan atau ditetapkan oleh pemerintah untuk dipertahankan keberadaannya sebagai hutan tetap. Konsekuensi langsung pemakaian definisi natural dan politik ini, hutan di Indonesia dapat berupa hamparan yang tidak terdapat pohonnya.

Pada pengertian hutan ini melekat urusan-urusan kehutanan yang diartikan sebagai sistem pengurusan yang bersangkutan paut dengan hutan, kawasan hutan, dan hasil hutan yang diselenggarakan secara terpadu, juga berlaku diluar kawasan hutan yang bukan dalam status hutan Negara.

UU No. 41 Tahun 1999 Tentang Kehutanan (UUK) pada bagian-bagian awal menetapkan hutan berdasarkan status yang merujuk kepada hak pemilikan dan berdasarkan fungsi yang merujuk kepada fungsi-fungsi ekologis yang ditetapkan oleh Departemen Kehutanan sebagai pemangku kawasan dan urusan kehutanan di Indonesia. Pada Pasal 5 UUK, hutan berdasarkan statusnya ditetapkan sebagai a) hutan negara, dan b) hutan hak. Posisi hutan adat diletakkan dalam ruang lingkup hutan Negara. Pengaturan demikian, memberikan pengertian bahwa hutan adat adalah hutan negara yang diserahkan pengelolaannya kepada masyarakat hukum adat (*rechtsgemeenschap*). Hutan adat tersebut sebelumnya disebut hutan ulayat, hutan marga, hutan pertuanan, atau sebutan lainnya. Sedangkan hutan hak, UUK mendefinisikannya sebagai sebagai hutan yang berada pada tanah yang dibebani hak milik lazim disebut hutan rakyat.

UUK menetapkan hutan berdasarkan tiga fungsi, yaitu a) fungsi konservasi, b) fungsi lindung, dan c) fungsi produksi. Hutan produksi adalah kawasan hutan yang mempunyai fungsi pokok memproduksi hasil hutan, hutan lindung adalah kawasan hutan yang mempunyai fungsi pokok sebagai perlindungan sistem penyangga kehidupan untuk mengatur tata air, mencegah banjir, mengendalikan erosi, mencegah intrusi air laut, dan memelihara kesuburan tanah, dan hutan konservasi adalah kawasan hutan dengan ciri khas tertentu, yang mempunyai fungsi pokok pengawetan keanekaragaman tumbuhan dan satwa serta ekosistemnya.

2. Kawasan Hutan Untuk Kepentingan Perkebunan

PP Nomor 47 Tahun 1997 Peraturan Pemerintah Tentang Rencana Tata Ruang Wilayah Nasional memperkenalkan Hutan Produksi Konversi yang nantinya akan menjadi areal-areal perkebunan. PP ini kemudian diganti dengan PP Nomor 26 Tahun 2008 Tentang Rencana Tata Ruang Wilayah Nasional. PP ini membagi kawasan-kawasan dalam rencana pola ruang wilayah nasional yaitu 10 kawasan lindung nasional dan kawasan budi daya yang memiliki nilai strategis nasional (Pasal 50).

HCV and RSPO: results of an investigation

Pengembangan perkebunan berada pada kawasan budi daya. Dibawah ini adalah pembagian kawasan budi daya berdasarkan rencana tata ruang nasional

Tabel 1. Bagan kawasan budi daya

Kawasan budi daya	Fungsi	Kreteria dan Syarat
kawasan peruntukan hutan produksi;	kawasan peruntukan hutan produksi terbatas;	Kawasan peruntukan hutan produksi terbatas ditetapkan dengan kriteria memiliki faktor kemiringan lereng, jenis tanah, dan intensitas hujan dengan jumlah skor 125 (seratus dua puluh lima) sampai dengan 174 (seratus tujuh puluh empat).
	kawasan peruntukan hutan produksi tetap;	Kawasan peruntukan hutan produksi tetap ditetapkan dengan kriteria memiliki faktor kemiringan lereng, jenis tanah, dan intensitas hujan dengan jumlah skor paling besar 124 (seratus dua puluh empat).
	kawasan peruntukan hutan produksi yang dapat dikonversi.	Kawasan peruntukan hutan produksi yang dapat dikonversi ditetapkan dengan kriteria: a. memiliki faktor kemiringan lereng, jenis tanah, dan intensitas hujan dengan jumlah skor paling besar 124 (seratus dua puluh empat); dan/atau b. merupakan kawasan yang apabila dikonversi mampu mempertahankan daya dukung dan daya tampung lingkungan.
kawasan peruntukan hutan rakyat;		
kawasan peruntukan pertanian;		
kawasan peruntukan perikanan;		
kawasan peruntukan pertambangan;		
kawasan peruntukan industri;		
kawasan peruntukan pariwisata;		
kawasan peruntukan permukiman; dan/atau kawasan peruntukan lainnya.		
Bagian Ketiga, Kawasan Budi Daya yang Memiliki Nilai	Paragraf 2, Kriteria Kawasan Budi Daya, Pasal 64	

Strategis Nasional, Paragraf 1 Kawasan Budi Daya, Pasal 63	
---	--

3. Aspek Hukum Usaha Perkebunan

Pembebasan lahan untuk kepentingan perkebunan menurut Keppres No. 55 tahun 1993 yang diganti oleh Perpres No. 36 tahun 2005 haruslah melalui mekanisme jual beli, tukar menukar, atau cara lain yang disepakati secara sukarela oleh pihak-pihak yang bersangkutan. Sementara itu di dua peraturan perundangan sebelumnya yaitu UU No. 20 Tahun 1961 dan Instruksi Presiden No. 9 Tahun 1973 membuka peluang pengadaan tanah untuk kepentingan perkebunan dapat memakai mekanisme kedua peraturan ini dengan alasan usaha tersebut mempunyai dimensi kepentingan umum.

Berdasarkan asal tanah, tanah perkebunan dapat dibagi atas dua yaitu tanah negara dan tanah yang hak atas tanahnya dikuasai langsung oleh masyarakat. Pengertian Tanah Negara pertama kali muncul pada Peraturan Pemerintah No. 8 Tahun 1953 Tentang Penguasaan Tanah-Tanah Negara. Dalam Pasal 1 huruf a disebutkan bahwa tanah negara adalah tanah yang dikuasai penuh oleh negara. Penjelasan umum PP ini menyebutkan bahwa

" Menurut "domeinverklaring" yang antara lain dinyatakan di dalam pasal I "Agrarisch Besluit", semua tanah yang bebas sama sekali dari pada hak-hak seseorang (baik yang berdasar atas hukum adat asli Indonesia, maupun yang berdasar atas hukum barat) di-anggap menjadi "vrij landsdomein" yaitu tanah-tanah yang dimiliki dan dikuasai penuh oleh Negara. Tanah-tanah demikian itulah yang di dalam Peraturan Pemerintah ini disebut "tanah Negara."

Sementara itu berdasarkan Pasal 1 angka 3 PP No. 24 tahun 1997 tentang pendaftaran tanah, tanah negara diartikan sebagai berikut:

Tanah Negara atau tanah yang dikuasai langsung oleh Negara adalah tanah yang tidak dipunyai dengan sesuatu hak atas tanah.

UU kehutanan mendefinisikan, kawasan hutan adalah wilayah tertentu yang ditunjuk dan atau ditetapkan oleh pemerintah untuk dipertahankan keberadaannya sebagai hutan tetap. Didalam kawasan hutan tersebut terdapat hutan negara berupa hutan yang berada pada tanah yang tidak dibebani hak atas tanah, hutan hak berupa hutan yang berada pada tanah yang dibebani hak atas tanah dan hutan adat berupa hutan negara yang berada dalam wilayah masyarakat hukum adat.

Kawasan hutan negara berada pada tanah yang tidak dibebani hak atas tanah sehingga merupakan tanah negara yang paling potensial untuk kepentingan pembangunan perkebunan. Karena itu berdasarkan rencana tata ruang nasional terdapat satu bagian kawasan budidaya yang direncanakan sebagai kawasan pengembangan perkebunan, kawasan ini populer disebut dengan Kawasan Hutan Konversi atau Hutan Produksi Konversi (HPK). Kawasan peruntukan hutan produksi yang dapat dikonversi ditetapkan dengan kriteria:

HCV and RSPO: results of an investigation

- a. memiliki faktor kemiringan lereng, jenis tanah, dan intensitas hujan dengan jumlah skor paling besar 124 (seratus dua puluh empat); dan/atau
- b. merupakan kawasan yang apabila dikonversi mampu mempertahankan daya dukung dan daya tampung lingkungan.

Kawasan hutan lain yang digunakan untuk kepentingan perkebunan adalah Areal Penggunaan Lain (APL) atau Kawasan Budidaya Non Kehutanan (KBNK). Areal Penggunaan Lain (APL) atau Kawasan Budidaya Non Kehutanan (KBNK) adalah areal hutan negara yang ditetapkan berdasarkan Keputusan Menteri Kehutanan tentang Penunjukan Kawasan Hutan dan Perairan Provinsi menjadi bukan kawasan hutan.

Penggunaan kawasan hutan untuk kepentingan perkebunan melalui proses pelepasan kawasan, setelah melewati prosedur perizinan perkebunan. Proses hukum usaha perkebunan secara berturut-turut sebagai berikut :

1. Mengajukan surat permohonan rekomendasi teknis kepada Menteri Pertanian c.q Pusat perizinan dan Investasi (PPI).
2. Mengajukan permohonan penanaman modal ke Badan Koordinasi Penanaman Modal (BKPM), dengan mengisi form I/PMDN.
3. Mengajukan surat permohonan pendirian perusahaan kepada Menteri Hukum dan HAM.
4. Mengajukan permohonan Nomor Pendaftaran Wajib Pajak (NPWP) kepada Ditjen Pajak, Departemen Keuangan.
5. Mengajukan surat permohonan persetujuan dokumen AMDAL/UKL/UPL.
6. Mengajukan surat permohonan kepada Gubernur/Bupati untuk memperoleh; 1) Izin lokasi, 2) IUP (Izin usaha perkebunan), 3) IUT, 4) Izin mendirikan bangunan (IMB), 5) Izin UU gangguan/HO, 6) Hak guna bangunan (HGB), dan 7) Sertifikat tanah.

Bagan dibawah menggambarkan alur penanaman modal dalam negeri perkebunan.

Usaha perkebunan di Indonesia, selain melewati alur proses penanaman modal sebagai langkah awal usaha, usaha perkebunan harus melewati empat proses hukum yaitu 1) proses izin lokasi, 2) proses izin usaha perkebunan, 3) proses pelepasan kawasan hutan dan 4) proses perolehan Hak Guna Usaha (HGU). Bagan dibawah menggambarkan aspek-aspek penting dari keempat proses investasi perkebunan tersebut.

Bagan 1. Alur PMDN Perkebunan

HCV and RSPO: results of an investigation

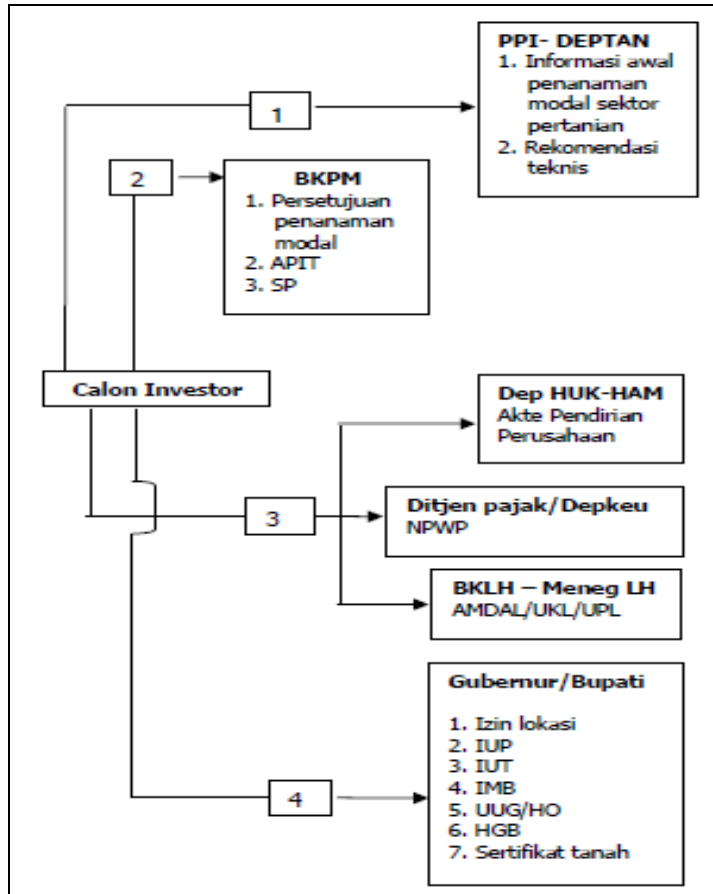

Bagan 2 : Bagan Perizinan Usaha Perkebunan di Indonesia.

HCV and RSPO: results of an investigation

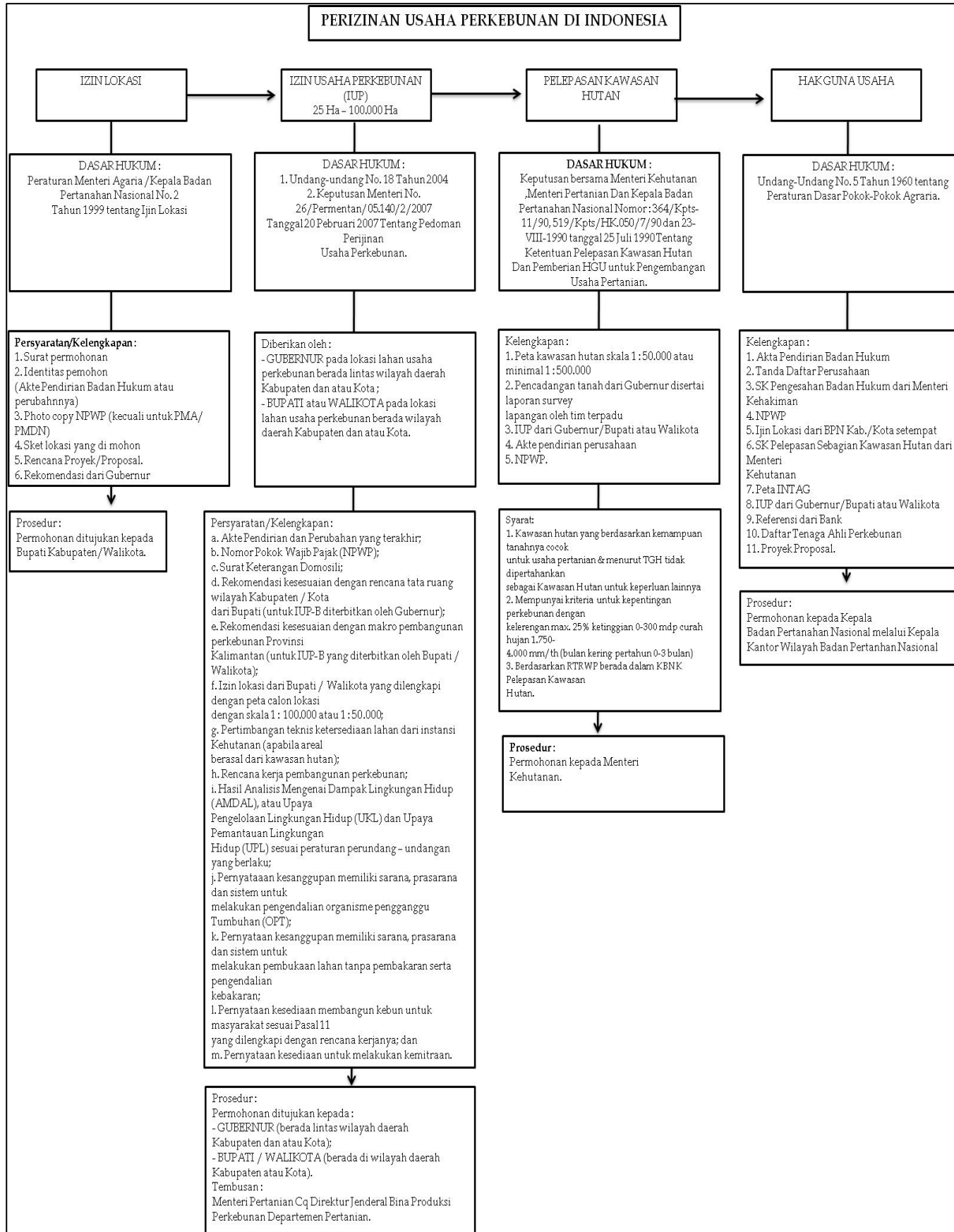

Izin Lokasi

Perolehan lahan akan dimulai oleh perusahaan perkebunan setelah memperoleh ijin lokasi dari Pemerintah Daerah Kabupaten/Kota setempat. Izin lokasi diatur dalam Peraturan Menteri Negara Agraria/Kepala Badan Pertanahan Negara No. 2 Tahun 1999 Tentang Izin Lokasi. Dalam konsideran menimbang disebutkan bahwa Izin lokasi dimaksudkan a) bahwa dalam rangka pengaturan penanaman modal telah ditetapkan ketentuan mengenai keharusan diperolehnya Izin Lokasi sebelum suatu perusahaan memperoleh tanah yang diperlukan untuk melaksanakan rencana penanaman modalnya, b) bahwa pemberian Izin Lokasi tersebut pada dasarnya merupakan pengarahannya lokasi penanaman modal sebagai pelaksanaan penataan ruang dalam aspek pertanahannya, c) bahwa pemberian Izin Lokasi tersebut telah diperluas sehingga meliputi juga izin untuk memperoleh tanah untuk keperluan yang tidak ada hubungannya dengan penanaman modal, dan d) bahwa untuk menjamin terlaksananya maksud Izin Lokasi sebagaimana dimaksud di atas, perlu mengembalikan fungsi Izin Lokasi tersebut dan membatasinya untuk keperluan penanaman modal dengan menetapkan ketentuan umum mengenai Izin Lokasi dalam Peraturan Menteri Negara Agraria/Kepala Badan Pertanahan Nasional.

BAB V

HAK DAN KEWAJIBAN PEMEGANG IZIN LOKASI

Pasal 8

- (1) Pemegang Izin Lokasi diizinkan untuk membebaskan tanah dalam areal Izin Lokasi hak dan kepentingan pihak lain berdasarkan kesepakatan dengan pemegang hak atau pihak yang mempunyai kepentingan tersebut dengan cara jual beli pemberian ganti kerugian, konsolidasi tanah atau cara lain sesuai ketentuan yang berlaku.
- (2) Sebelum tanah yang bersangkutan dibebaskan oleh pemegang Izin Lokasi sesuai ketentuan pada ayat (1), maka semua hak atau kepentingan pihak lain yang sudah ada atas tanah yang bersangkutan tidak berkurang dan tetap diakui, termasuk kewenangan yang menurut hukum dipunyai oleh pemegang hak atas tanah untuk memperoleh tanda bukti hak (sertifikat) dan kewenangan untuk menggunakan dan memanfaatkan tanahnya bagi keperluan pribadi atau usahanya sesuai rencana tata ruang yang berlaku, serta kewenangan untuk mengalihkannya kepada pihak lain.
- (3) Pemegang Izin Lokasi wajib menghormati kepentingan pihak-pihak lain atas tanah yang belum dibebaskan sebagaimana dimaksud pada ayat (1), tidak menutup atau mengurangi aksesibilitas yang dimiliki masyarakat di sekitar lokasi, dan menjaga serta melindungi kepentingan umum
- (4) Sesudah tanah yang bersangkutan dibebaskan dari hak dan kepentingan pihak lain, maka kepada pemegang Izin Lokasi dapat diberikan hak atas tanah yang memberikan kewenangan kepadanya untuk menggunakan tanah tersebut sesuai dengan keperluan untuk melaksanakan rencana penanaman modalnya.

Pasal 9

Pemegang Izin Lokasi berkewajiban untuk melaporkan secara berkala setiap 3 (tiga) bulan kepada Kantor Pertanahan mengenai perolehan tanah yang sudah dilaksanakannya berdasarkan Izin Lokasi dan pelaksanaan penggunaan tanah tersebut.

Izin Lokasi adalah izin yang diberikan kepada perusahaan untuk memperoleh tanah yang diperlukan dalam rangka penanaman modal yang berlaku pula sebagai izin pemindahan hak, dan untuk menggunakan tanah tersebut guna keperluan usaha penanaman modalnya. Izin lokasi ini diwajibkan untuk setiap penanaman modal (PMA & PMDN), tetapi dalam kondisi tertentu, ijin lokasi tidak diperlukan apabila a) Tanah yang akan diperoleh merupakan pemasukan (*inbrens*) daripada pemegang

saham, b) Tanah yang akan diperoleh merupakan tanah yang sudah dikuasai oleh perusahaan lain dalam rangka melanjutkan pelaksanaan sebagian atau seluruh rencana penanaman modal perusahaan lain tersebut dan untuk itu telah diperoleh persetujuan dari Instansi yang berwenang, c) Tanah yang akan diperoleh diperlukan dalam rangka melaksanakan usaha industri dalam suatu kawasan industri, d) Tanah yang akan diperoleh berasal dari otorita atau badan penyelenggara pengembangan suatu kawasan sesuai dengan rencana tata ruang pengembangan kawasan tersebut, e) Tanah yang akan diperoleh diperlukan untuk perluasan usaha yang sudah berjalan dan untuk perluasan itu telah diperoleh izin perluasan usaha sesuai ketentuan yang berlaku, sedangkan letak tanah tersebut berbatasan dengan lokasi usaha yang bersangkutan, f) Tanah yang diperlukan untuk melaksanakan rencana penanaman modal tidak lebih dari 25 Ha untuk usaha pertanian atau tidak lebih dari 10.000 m² untuk usaha bukan pertanian, d) Tanah yang akan dipergunakan untuk melaksanakan rencana penanaman modal adalah tanah yang sudah dipunyai oleh perusahaan yang bersangkutan dengan ketentuan bahwa tanah-tanah tersebut terletak di lokasi yang menurut rencana tata ruang wilayah yang berlaku diperuntukkan bagi penggunaan yang sesuai dengan rencana penanaman modal yang bersangkutan.

Jangka waktu Izin lokasi diberikan berdasarkan luasan tanah yang dibutuhkan. Apabila luasan tanah yang dibutuhkan untuk investasi adalah sampai dengan 25 Ha maka izin lokasi diberikan selama 1 tahun, untuk tanah seluas 25 s/d 50 Ha, diberikan waktu selama 2 tahun dan untuk luasan lebih 50 Ha waktu yang diberikan adalah 3 tahun. Jika dalam masa satu izin lokasi, pembebasan lahan belum sampai pada luasan yang dibutuhkan, tapi telah mencapai lebih dari 50% dari luas tanah yang ditunjuk dalam izin lokasi tersebut, maka perpanjangan dapat diberikan selama 1 tahun. Tapi jika perolehan tanah tidak dapat diselesaikan pada masa izin lokasi dan perpanjangannya, maka pada tanah-tanah yang sudah dapat diperoleh ditentukan tindakan-tindakan a) dipergunakan untuk melaksanakan rencana penanaman modal dengan penyesuaian mengenai luas pembangunan dengan ketentuan bahwa apabila diperlukan masih dapat dilaksanakan perolehan tanah sehingga diperoleh bidang tanah yang merupakan satu kesatuan bidang atau b) dilepaskan kepada perusahaan atau pihak lain yang memenuhi syarat.

Dalam Peraturan Menteri Negara Agraria/Kepala Badan Pertanahan Negara No. 2 Tahun 1999 Tentang Izin Lokasi ini ditentukan batasan maksimum penguasaan lahan. Untuk perkebunan, izin lokasi dapat diberikan kepada perusahaan yang sudah mendapat persetujuan penanaman modal untuk memperoleh tanah dengan luas tertentu sehingga apabila perusahaan tersebut berhasil membebaskan seluruh areal yang ditunjuk, maka luas penguasaan tanah oleh perusahaan tersebut dan perusahaan-perusahaan lain yang merupakan suatu group perusahaan dengannya tidak lebih dari luasan sebagai berikut: 1) untuk komoditas tebu, luasan 1 provinsi, tidak lebih dari 60.000 Ha dan untuk seluruh Indonesia tidak lebih dari 150.000 Ha dan 2) untuk perkebunan komoditas lainnya ditentukan luasan maksimal untuk 1 provinsi adalah 20.000 Ha dan untuk seluruh Indonesia 100.000 Ha.

Surat keputusan pemberian Izin Lokasi ditandatangani oleh Bupati/Walikota atau, untuk Daerah Khusus Ibukota Jakarta, oleh Gubernur Kepala Daerah Khusus Ibukota Jakarta setelah diadakan rapat koordinasi antar instansi terkait, yang dipimpin oleh Bupati/Walikota atau untuk Daerah Khusus Ibukota Jakarta, oleh Gubernur Kepala Daerah Khusus Ibukota Jakarta, atau oleh pejabat yang ditunjuk

HCV and RSPO: results of an investigation

secara tetap olehnya dan diberikan berdasarkan pertimbangan mengenai aspek penguasaan tanah dan teknis tata guna tanah yang meliputi keadaan hak serta penguasaan tanah yang bersangkutan, penilaian fisik wilayah, penggunaan tanah serta kemampuan tanah.

Kepala Badan Pertanahan Nasional (BPN) setempat menyelenggarakan rapat koordinasi untuk memberikan pertimbangan kepada Kepala Daerah dimana terdapat kewajiban untuk berkonsultasi dengan pemegang hak atas tanah yang mencakup aspek-aspek a) penyebarluasan informasi, mengenai rencana penanaman modal yang akan dilaksanakan, ruang lingkup dampaknya dan rencana perolehan tanah serta penyelesaian masalah yang berkenaan dengan perolehan tanah tersebut, b) Pembebasan kesempatan kepada pemegang hak atas tanah untuk memperoleh penjelasan tentang rencana penanaman modal dan mencari alternatif pemecahan masalah yang ditemui, c) Pengumpulan informasi langsung dari masyarakat untuk memperoleh data sosial dan lingkungan yang diperlukan dan d) Peran serta masyarakat berupa usulan tentang alternatif bentuk dan besarnya ganti kerugian dalam perolehan tanah dalam pelaksanaan Izin Lokasi.

Pasal 8 menentukan, setelah pengusaha perkebunan memperoleh ijin lokasi, pengusaha perkebunan ini berhak untuk membebaskan tanah dalam areal Izin Lokasi, hak dan kepentingan pihak lain berdasarkan kesepakatan dengan pemegang hak atau pihak yang mempunyai kepentingan tersebut dengan cara jual beli pemberian ganti kerugian, konsolidasi tanah atau cara lain sesuai ketentuan yang berlaku. Sebelum tanah yang bersangkutan dibebaskan oleh pemegang Izin Lokasi, maka semua hak atau kepentingan pihak lain yang sudah ada atas tanah yang bersangkutan tidak berkurang dan tetap diakui, termasuk kewenangan yang menurut hukum dimiliki oleh pemegang hak atas tanah untuk memperoleh tanda bukti hak (sertifikat) dan kewenangan untuk menggunakan dan memanfaatkan tanahnya bagi keperluan pribadi atau usahanya sesuai rencana tata ruang yang berlaku, serta kewenangan untuk mengalihkannya kepada pihak lain. Pemegang Izin Lokasi wajib menghormati kepentingan pihak-pihak lain atas tanah yang belum dibebaskan, tidak menutup atau mengurangi aksesibilitas yang dimiliki masyarakat di sekitar lokasi, dan menjaga serta melindungi kepentingan umum. Sesudah tanah yang bersangkutan dibebaskan dari hak dan kepentingan pihak lain, maka kepada pemegang Izin Lokasi dapat diberikan hak atas tanah yang memberikan kewenangan kepadanya untuk menggunakan tanah tersebut sesuai dengan keperluan untuk melaksanakan rencana penanaman modalnya.

Izin Perkebunan

Izin usaha perkebunan diatur dalam Peraturan Menteri Pertanian Nomor 26/Permentan/OT.140/2/2007 Tentang Pedoman Perizinan Usaha Perkebunan. Pasal 17 menentukan bahwa untuk memperoleh IUP, perusahaan perkebunan mengajukan permohonan secara tertulis kepada bupati/walikota atau gubernur sesuai dengan lokasi areal dengan dilengkapi persyaratan sebagai berikut:

HCV and RSPO: results of an investigation

1. Akte pendirian perusahaan dan perubahannya yang terakhir;
2. Nomor Pokok Wajib Pajak;
3. Surat keterangan domisili;
4. Rekomendasi kesesuaian dengan rencana tata ruang wilayah kabupaten/kota dari bupati/walikota untuk IUP yang diterbitkan oleh gubernur;
5. Rekomendasi kesesuaian dengan rencana makro pembangunan perkebunan provinsi dari gubernur untuk IUP yang diterbitkan oleh bupati/walikota;
6. Izin lokasi dari bupati/walikota yang dilengkapi dengan peta calon lokasi dengan skala 1 : 100.000 atau 1 : 50.000;
7. Pertimbangan teknis ketersediaan lahan dari instansi Kehutanan (apabila areal berasal dari kawasan hutan);
8. Jaminan pasokan bahan baku yang diketahui oleh bupati/walikota;
9. Rencana kerja pembangunan kebun dan unit pengolahan hasil perkebunan;
10. Hasil Analisis Mengenai Dampak Lingkungan Hidup (AMDAL), atau Upaya Pengelolaan Lingkungan Hidup (UKL) dan Upaya Pemantauan Lingkungan Hidup (UPL) sesuai peraturan perundang-undangan yang berlaku;
11. Pernyataan perusahaan belum menguasai lahan melebihi batas luas maksimum;
12. Pernyataan kesanggupan memiliki sarana, prasarana dan sistem untuk melakukan pengendalian organisme pengganggu tumbuhan (OPT);
13. Pernyataan kesanggupan memiliki sarana, prasarana dan sistem untuk melakukan pembukaan lahan tanpa pembakaran serta pengendalian kebakaran;
14. Pernyataan kesediaan dan rencana kerja pembangunan kebun untuk masyarakat
15. Pernyataan kesediaan dan rencana kerja kemitraan.

Pelepasan Kawasan Hutan

Prosedur pelepasan kawasan hutan untuk kepentingan perkebunan diatur dalam Keputusan Bersama Menteri Kehutanan, Menteri Pertanian Dan BPN NO. 364/KPTS-II/1990, 519/KPTS/HK.050/7/1990, 223-VIII-1990 Tentang Ketentuan Pelepasan Kawasan Hutan Dan Pemberian Hak Guna Usaha Untuk Pengembangan Usaha Pertanian. Dibawah ini adalah bagan prosedur pelepasan kawasan hutan tersebut.

Bagan 3. Prosedur Pelepasan Kawasan Hutan

HCV and RSPO: results of an investigation

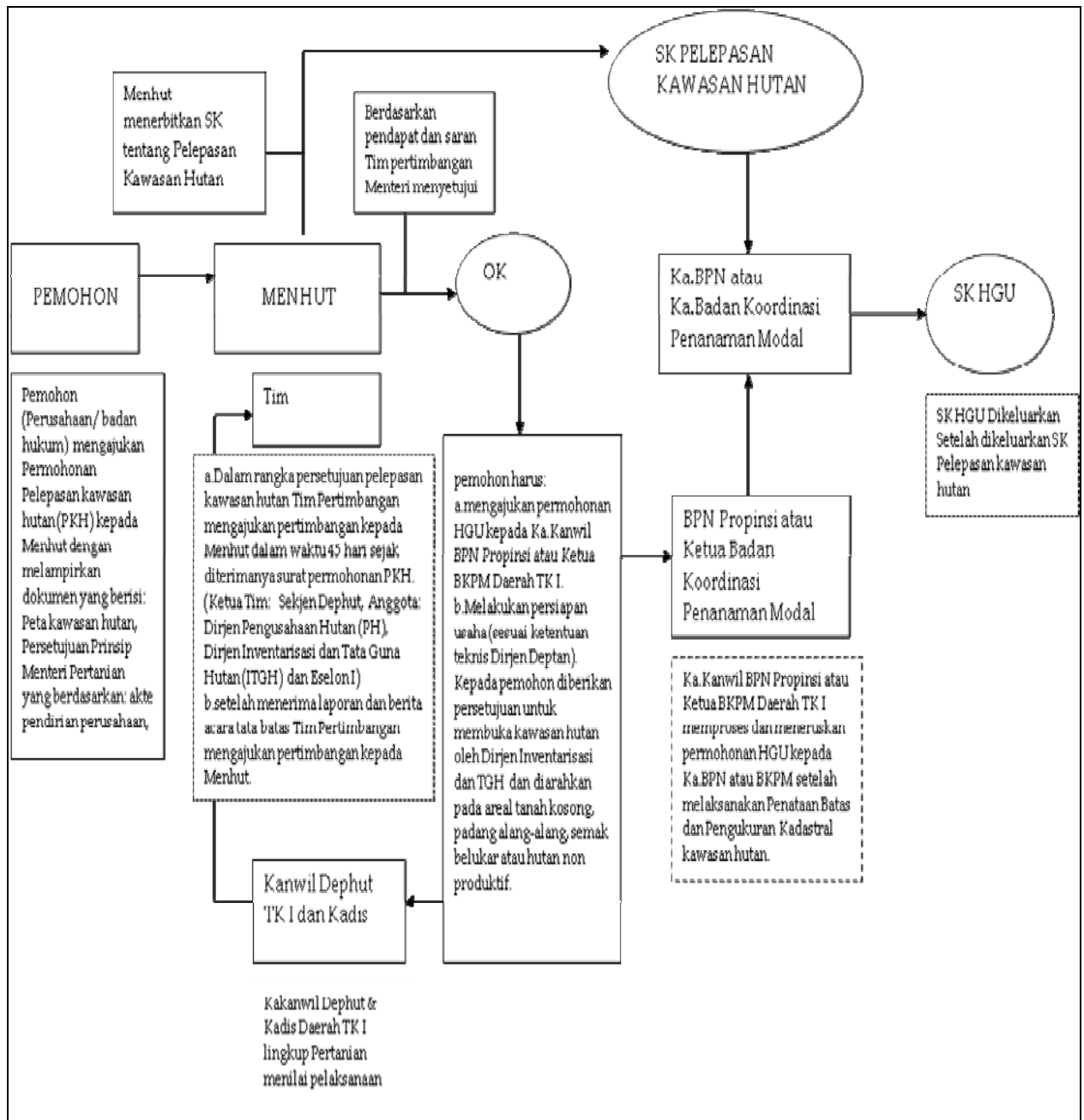

Poin penting dari surat keputusan bersama menteri (SKB) tentang pedoman pelepasan kawasan hutan ini adalah pelepasan kawasan hutan untuk kepentingan perkebunan diarahkan pada areal tanah kosong, padang alang-alang, semak belukar atau hutan non produktif yang sesuai untuk usaha pertanian yang bersangkutan.

Selama SKB ini berlaku, banyak terjadi penyimpangan-penyimpangan. Setelah kawasan hutan dilepaskan, usaha perkebunan yang direncanakan tidak terealisasi dan dicurigai, pelepasan kawasan hutan ini hanya untuk mengambil hasil hutan kayu saja. Karena itu pada tahun 2003 Menteri kehutanan menerbitkan Keputusan Menteri Kehutanan Nomor : 146/Kpts-II/2003 Tentang Pedoman Evaluasi Penggunaan Kawasan Hutan/ Ex Kawasan Hutan Untuk Pengembangan Usaha Budidaya Perkebunan Menteri Kehutanan. Keputusan menteri ini dilahirkan berdasarkan pertimbangan bahwa berdasarkan Keputusan Bersama Menteri Kehutanan, Menteri Pertanian dan Kepala Badan Pertanahan Nasional Nomor 364/Kpts-II/90; Nomor

519/Kpts/HK.050/7/90 dan Nomor 23-VIII-90 tanggal 25 Juli 1990, telah ditetapkan ketentuan dan persyaratan tentang Pelepasan Kawasan Hutan dan Pemberian HGU untuk Pengembangan Usaha Pertanian. Tetapi berdasarkan kenyataan masih banyak pemohon yang mendapat persetujuan pencadangan atau Surat Keputusan Pelepasan Kawasan Hutan, namun tidak melaksanakan ketentuan yang ditetapkan.

Hak Guna Usaha (HGU)

Hak Guna Usaha diatur dalam UUPA dan PP No. 24 Tahun 1997 Tentang Pendaftaran Tanah dan PP No. 40 Tahun 1996 Tentang Hak Guna Usaha, Hak Guna Bangunan Dan Hak Pakai Atas Tanah.

Pada Bagian Kelima yang mengatur Kewajiban dan Hak Pemegang Hak Guna Usaha,

Pasal 12 PP No. 40 Tahun 1996 menentukan bahwa

- (1) Pemegang Hak Guna Usaha berkewajiban untuk:
 - a. membayar uang pemasukan kepada Negara;
 - b. melaksanakan usaha pertanian, perkebunan, perikanan dan/atau peternakan sesuai peruntukan dan persyaratan sebagaimana ditetapkan dalam keputusan pemberian haknya;
 - c. mengusahakan sendiri tanah Hak Guna Usaha dengan baik sesuai dengan kelayakan usaha berdasarkan kriteria yang ditetapkan oleh instansi teknis;
 - d. membangun dan memelihara prasarana lingkungan dan fasilitas tanah yang ada dalam lingkungan areal Hak Guna Usaha;
 - e. memelihara kesuburan tanah, mencegah kerusakan sumber daya alam dan menjaga kelestarian kemampuan lingkungan hidup sesuai dengan peraturan perundang-undangan yang berlaku;
 - f. menyampaikan laporan tertulis setiap akhir tahun mengenai penggunaan Hak Guna Usaha;
 - g. menyerahkan kembali tanah yang diberikan dengan Hak Guna Usaha kepada Negara sesudah Hak Guna Usaha tersebut habis;
 - h. menyerahkan sertipikat Hak Guna Usaha yang telah habis kepada Kepala Kantor Pertanahan.
- (2) Pemegang Hak Guna Usaha dilarang menyerahkan pengusahaan tanah Hak Guna Usaha kepada pihak lain, kecuali dalam hal-hal diperbolehkan menurut peraturan perundang-undangan yang berlaku.

Selanjutnya pada Pasal 13 ditentukan jika tanah Hak Guna Usaha karena keadaan geografis atau lingkungan atau sebab-sebab lain letaknya sedemikian rupa sehingga mengurung atau menutup pekarangan atau bidang tanah lain dari lalu lintas umum atau jalan air, maka pemegang Hak Guna Usaha wajib memberikan jalan keluar atau jalan air atau kemudahan lain bagi pekarangan atau bidang tanah yang terkurung itu.

Pada Pasal 17 diatur mengenai hapusnya Hak Guna Usaha yang mengakibatkan tanahnya menjadi tanah Negara. Hapusnya HGU karena:

- a. berakhirnya jangka waktu sebagaimana ditetapkan dalam keputusan pemberian atau perpanjangannya;
- b. dibatalkan haknya oleh pejabat yang berwenang sebelum jangka waktunya berakhir karena:

HCV and RSPO: results of an investigation

- (1) tidak terpenuhinya kewajiban-kewajiban pemegang hak dan/atau dilanggarnya ketentuan-ketentuan sebagaimana dimaksud dalam Pasal 12, Pasal 13 dan/atau Pasal 14;
 - (2) putusan pengadilan yang telah mempunyai kekuatan hukum tetap;
- c. dilepaskan secara sukarela oleh pemegang haknya sebelum jangka waktunya berakhir;
 - d. dicabut berdasarkan Undang-undang Nomor 20 Tahun 1961;
 - e. ditelantarkan;
 - f. tanahnya musnah;
 - g. ketentuan Pasal 3 ayat (2).

Berdasarkan Peraturan Menteri Negara Agraria/Kepala Badan Pertanahan Negara No. 3 Tahun 1999, wewenang pemberian hak atas tanah adalah sebagai berikut:

- 1) Hak Guna Usaha (HGU) diberikan oleh:
 - a) BPN: untuk luas tanah lebih dari 200 Ha;
 - b) Kantor Wilayah BPN Provinsi: untuk luas sampai dengan 200 Ha.
- 2) Hak Guna Bangunan (HGB) diberikan oleh:
 - a) BPN: untuk luas lebih dari 15 Ha;
 - b) Kantor Wilayah BPN Provinsi: untuk luas lebih dari 2000 m² sampai dengan 15 Ha;
 - c) Kantor Wilayah BPN Kabupaten/Kota: untuk luas sampai dengan 2000 m².
- 3) Hak Pakai (HP) Pertanian diberikan oleh:
 - a) Kantor Wilayah BPN Provinsi: untuk luas lebih dari 2 Ha;
 - b) Kantor Wilayah BPN Kabupaten/Kota: untuk luas sampai dengan 2 Ha.
- 4) Hak Pakai (HP) Non Pertanian diberikan oleh:
 - a) BPN: untuk luas lebih dari 15 Ha;
 - b) Kantor Wilayah BPN Provinsi: untuk luas lebih dari 2000 m² sampai dengan 15 Ha;
 - c) Kantor Wilayah BPN Kabupaten/Kota: untuk luas sampai dengan 2000 m².

Ruang Hukum Kepastian Status HCV

Pada tahun 2004, putaran perundingan para pihak yang terlibat dalam industri minyak sawit dimulai. Putaran perundingan yang didorong oleh pelaku pasar dan melibatkan masyarakat serta NGO ditujukan untuk melahirkan standard dan kriteria minyak sawit yang lestari. Roundtable Sustainable Palm Oil (RSPO) mendiskusikan salah satu topic hangat yaitu mengenai High Conservation Value Forest (HCVF) atau hutan dengan nilai konservasi tinggi. Hutan dengan Nilai Konservasi Tinggi adalah kawasan hutan yang memiliki satu atau lebih ciri-ciri berikut:

- 1) HCV1 Kawasan hutan yang mempunyai konsentrasi nilai-nilai keanekaragaman hayati yang penting secara global, regional dan lokal (misalnya spesies endemi, spesies hampir punah, tempat menyelamatkan diri (refugia)).
- 2) HCV2 Kawasan hutan yang mempunyai tingkat lanskap yang luas yang penting secara global, regional dan lokal, yang berada di dalam atau mempunyai unit pengelolaan,
- 3) dimana sebagian besar populasi species, atau seluruh species yang secara alami ada dikawasan tersebut berada dalam pola-pola distribusi dan kelimpahan alami.

HCV and RSPO: results of an investigation

- 4) HCV3 Kawasan hutan yang berada didalam atau mempunyai ekosistem yang langka, terancam atau hampir punah.
- 5) HCV4 Kawasan hutan yang berfungsi sebagai pengatur alam dalam situasi yang kritis (e.g. perlindungan daerah aliran sungai, pengendalian erosi).
- 6) HCV5 Kawasan hutan yang sangat penting untuk memenuhi kebutuhan dasar masyarakat lokal (misal, pemenuhan kebutuhan pokok, kesehatan)
- 7) HCV6 Kawasan hutan yang sangat penting untuk identitas budaya tradisional masyarakat lokal (kawasan-kawasan budaya, ekologi, ekonomi, agama yang penting yang diidentifikasi bersama dengan masyarakat lokal yang bersangkutan) .

Konsep HCVF ini dikembangkan oleh Forest Stewardship Council (FSC), sebuah Lembaga sertifikasi internasional sejak tahun 1999 dan memasukkannya dalam prinsip dan kriteria sertifikasi hutan. Prinsip dan kriteria RSPO kemudian mengadopsi HCVF ini pada Prinsip 7 mengenai pengembangan perkebunan baru yang bertanggung jawab. HCVF merupakan bagian dari Kriteria 7.1. yang menyatakan bahwa dalam memnuhi prinsip 7 tersebut diperlukan suatu kajian lingkungan dan sosial yang komprehensif dan partisipatif dilakukan sebelum menetapkan suatu wilayah baru perkebunan atau operasi, atau perluasan kawasan yg sudah ada, dan hasilnya diintegrasikan ke dalam perencanaan, pengelolaan dan operasi. Untuk itu diperlukan panduan yang berisi:

- 1) Menjelaskan siapa yg harus berpartisipasi
- 2) Independen, tidak berkonflik, dan professional
- 3) Jelaskan bagaimana melakukan kajian HCVF

Di lapangan, sebagai akibat dari identifikasi HCVF, terdapat potongan-potongan landscape hutan pada hamparan konsesi perkebunan. Potongan-potongan hutan HCVF ini menjadi bagian baru dari pengelolaan fisik yang harus dijalankan oleh perusahaan perkebunan.

Bagian ini mencoba untuk memberikan analisa hokum perlindungan HCV dalam proses usaha perkebunan dalam hokum Indonesia.

HCV dalam Izin Lokasi

BAB V, Pasal 8, Peraturan Menteri Negara Agraria/Kepala Badan Pertanahan Negara No. 2 Tahun 1999 Tentang Izin Lokasi menentukan bahwa

- (1) Pemegang Izin Lokasi diizinkan untuk membebaskan tanah dalam areal Izin Lokasi hak dan kepentingan pihak lain berdasarkan kesepakatan dengan pemegang hak atau pihak yang mempunyai kepentingan tersebut dengan cara jual beli pemberian ganti kerugian, konsolidasi tanah atau cara lain sesuai ketentuan yang berlaku.
- (2) Sebelum tanah yang bersangkutan dibebaskan oleh pemegang Izin, maka semua hak atau kepentingan pihak lain yang sudah ada atas tanah yang bersangkutan tidak berkurang dan tetap diakui, termasuk kewenangan yang menurut hukum dipunyai oleh pemegang hak atas tanah untuk memperoleh tanda bukti hak (sertifikat) dan kewenangan untuk menggunakan dan memanfaatkan tanahnya

HCV and RSPO: results of an investigation

- bagi keperluan pribadi atau usahanya sesuai rencana tata ruang yang berlaku, serta kewenangan untuk mengalihkannya kepada pihak lain.
- (3) Pemegang Izin Lokasi wajib menghormati kepentingan pihak-pihak lain atas tanah yang belum dibebaskan, tidak menutup atau mengurangi aksesibilitas yang dimiliki masyarakat di sekitar lokasi, dan menjaga serta melindungi kepentingan umum
 - (4) Sesudah tanah yang bersangkutan dibebaskan dari hak dan kepentingan pihak lain, maka kepada pemegang Izin Lokasi dapat diberikan hak atas tanah yang memberikan kewenangan kepadanya untuk menggunakan tanah tersebut sesuai dengan keperluan untuk melaksanakan rencana penanaman modalnya.

Sedangkan pada Pasal 9 ditentukan bahwa Pemegang Izin Lokasi berkewajiban untuk melaporkan secara berkala setiap 3 (tiga) bulan kepada Kantor Pertanahan mengenai perolehan tanah yang sudah dilaksanakannya berdasarkan Izin Lokasi dan pelaksanaan penggunaan tanah tersebut.

Ayat 2) dan Ayat 3) Pasal 8 Permen Izin Lokasi diatas dapat digunakan sebagai landasan untuk melindungi kawasan-kawasan HCV sepanjang kawasan tersebut terdapat hak atau kepentingan pihak lain dan aksesibilitas masyarakat di sekitar lokasi, serta kepentingan umum. HCV perlu ditempatkan menjadi bagian penting dalam hubungannya dengan kepentingan masyarakat dan kepentingan umum setempat. Langkah pentingnya adalah memastikan alasan-alasan ini tidak menyebabkan perusahaan menghindar dari kewajiban untuk mengelola dan melindungi HCV yang telah teridentifikasi dalam perencanaan perkebunan.

HCV dalam AMDAL Perkebunan

AMDAL adalah bagian penting dalam proses perizinan perkebunan. Salah satu syarat adanya izin perkebunan adalah Hasil Analisis Mengenai Dampak Lingkungan Hidup (AMDAL), atau Upaya Pengelolaan Lingkungan Hidup (UKL) dan Upaya Pemantauan Lingkungan Hidup (UPL).

Pengertian Penting

Analisis Mengenai Dampak Lingkungan Hidup menentukan bahwa analisis mengenai dampak lingkungan hidup (AMDAL) adalah kajian mengenai dampak besar dan penting suatu usaha dan/atau kegiatan yang direncanakan pada lingkungan hidup yang diperlukan bagi proses pengambilan keputusan tentang penyelenggaraan usaha dan/atau kegiatan.

Dampak besar dan penting adalah perubahan lingkungan hidup yang sangat mendasar yang diakibatkan oleh suatu usaha dan/atau kegiatan. Kerangka acuan adalah ruang lingkup kajian analisis mengenai dampak lingkungan hidup yang merupakan hasil pelingkupan.

Analisis dampak lingkungan hidup (ANDAL) adalah telaahan secara cermat dan mendalam tentang dampak besar dan penting suatu rencana usaha dan/atau kegiatan. Rencana pengelolaan lingkungan hidup (RKL) adalah upaya penanganan dampak besar dan penting terhadap lingkungan hidup yang ditimbulkan akibat dari rencana usaha dan/atau kegiatan.

Rencana pemantauan lingkungan hidup (RPL) adalah upaya pemantauan komponen lingkungan hidup yang terkena dampak besar dan penting akibat dari rencana usaha dan/atau kegiatan.

HCV and RSPO: results of an investigation

Peraturan Pemerintah No. 27 Tahun 1999 Tentang AMDAL menentukan bahwa usaha dan/atau kegiatan yang kemungkinan dapat menimbulkan dampak besar dan penting terhadap lingkungan hidup wajib memiliki AMDAL. Usaha tersebut meliputi :

1. perubahan bentuk lahan dan bentang alam;
2. eksploitasi sumber daya alam baik yang terbarui maupun yang tak terbarui;
3. proses dan kegiatan yang secara potensial dapat menimbulkan pemborosan, pencemaran dan kerusakan lingkungan hidup, serta kemerosotan sumber daya alam dalam pemanfaatannya;
4. proses dan kegiatan yang hasilnya dapat mempengaruhi lingkungan alam, lingkungan buatan, serta lingkungan sosial dan budaya;
5. proses dan kegiatan yang hasilnya akan dapat mempengaruhi pelestarian kawasan konservasi sumber daya alam dan/atau perlindungan cagar budaya;
6. introduksi jenis tumbuh-tumbuhan, jenis hewan, dan jasad renik;
7. pembuatan dan penggunaan bahan hayati dan non-hayati;
8. penerapan teknologi yang diperkirakan mempunyai potensi besar untuk mempengaruhi lingkungan hidup;
9. kegiatan yang mempunyai risiko tinggi, dan/atau mempengaruhi pertahanan negara.

Kriteria mengenai dampak besar dan penting suatu usaha dan/atau kegiatan terhadap lingkungan hidup antara lain :

1. jumlah manusia yang akan terkena dampak;
2. luas wilayah persebaran dampak;
3. intensitas dan lamanya dampak berlangsung;
4. banyaknya komponen lingkungan lainnya yang terkena dampak;
5. sifat kumulatif dampak;
6. berbalik (reversible) atau tidak berbaliknya (irreversible) dampak.

Usaha-usaha perkebunan termasuk kedalam kategori usaha yang wajib memiliki AMDAL. Tata cara penyusunan analisa dampak lingkungan di atur dalam Peraturan Menteri Lingkungan Hidup No. 8 Tahun 2006 Tentang Pedoman Penyusunan Kerangka Acuan ANDAL. Permen ini mensyaratkan komponen lingkungan hidup yang harus dipertahankan dan harus memperhatikan perubahan yang akan timbul dari lingkungan hidup tersebut. Bagan dibawah ini menggambarkan komponen-komponen tersebut.

Bagan 4. Komponen Lingkungan Hidup dalam ANDAL

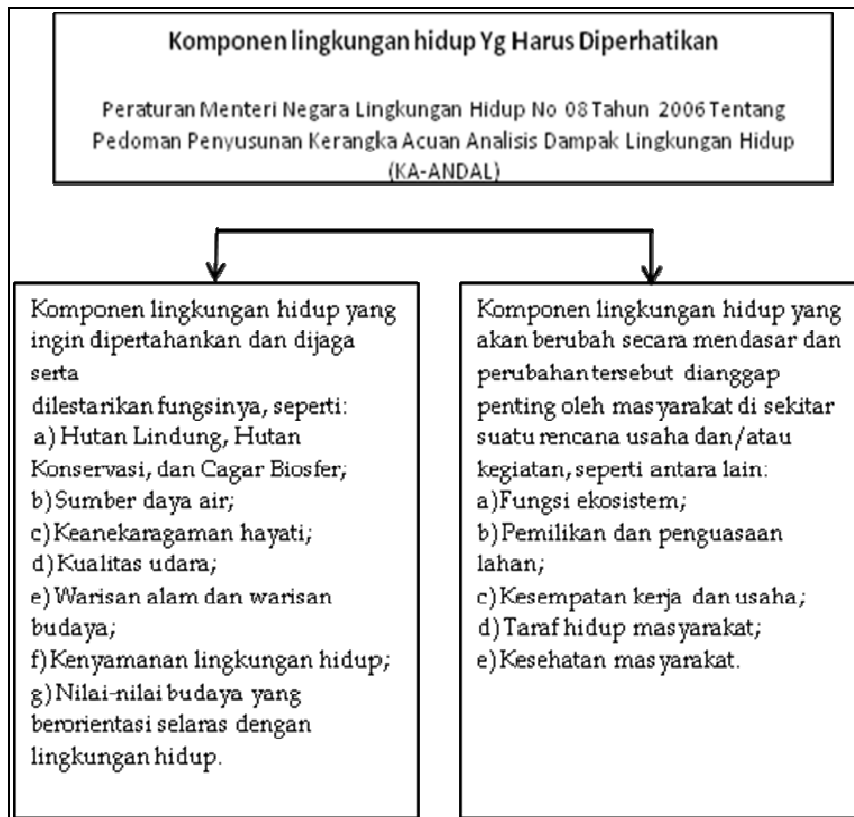

HCV adalah bagian penting yang harus diidentifikasi dalam dokumen AMDAL. Selain identifikasi, pengelolaan HCV harus termasuk kedalam dokumen rencana pemantauan lingkungan hidup (RPL) yang merupakan upaya pemantauan komponen lingkungan hidup yang terkena dampak besar dan penting akibat dari rencana usaha dan/atau kegiatan. Semestinya dalam proses penilaian dokumen AMDAL, HCV harus menjadi poin penting yang dinilai.

HCV dalam Pelepasan Kawasan Hutan

Pelepasan Kawasan Hutan adalah pengubahan status kawasan hutan menjadi tanah yang dikuasai langsung oleh Negara untuk keperluan usaha pertanian. Proses pelepasan kawasan hutan dilaksanakan sesuai dengan yang diuraikan pada bagian sebelumnya.

Posisi kunci pengaman HCV berdasarkan proses tersebut berada pada Tim Pertimbangan yang memberikan pertimbangan dan saran dalam rangka persetujuan pelepasan kawasan hutan, yang terdiri dari Sekretaris Jenderal, Direktur Jenderal Pengusahaan Hutan, Direktur Jenderal Inventarisasi dan Tata Guna hutan dan Eselon I Departemen Kehutanan yang terkait.

Meskipun persetujuan pelepasan kawasan hutan untuk kepentingan perkebunan lebih banyak berupa pertimbangan teknis administrative, tim pertimbangan dapat mempertinggi standar pertimbangan dengan mensyaratkan pengamanan dan pengelolaan HCV. Tetapi perlu dipertimbangkan, setelah persetujuan pelepasan kawasan hutan diterima oleh perusahaan, kawasan tersebut berada dalam pengawasan pemerintah daerah.

HCV dalam HGU

Seperti yang diuraikan diatas, pada Bagian Kelima yang mengatur Kewajiban dan Hak Pemegang Hak Guna Usaha, Pasal 12 ayat (1) PP No. 40 Tahun 1996 ditentukan bahwa pemegang Hak Guna Usaha berkewajiban untuk:

- a. membayar uang pemasukan kepada Negara;
- b. melaksanakan usaha pertanian, perkebunan, perikanan dan/atau peternakan sesuai peruntukan dan persyaratan sebagaimana ditetapkan dalam keputusan pemberian haknya;
- c. mengusahakan sendiri tanah Hak Guna Usaha dengan baik sesuai dengan kelayakan usaha berdasarkan kriteria yang ditetapkan oleh instansi teknis;
- d. membangun dan memelihara prasarana lingkungan dan fasilitas tanah yang ada dalam lingkungan areal Hak Guna Usaha;
- e. memelihara kesuburan tanah, mencegah kerusakan sumber daya alam dan menjaga kelestarian kemampuan lingkungan hidup sesuai dengan peraturan perundang-undangan yang berlaku;
- f. menyampaikan laporan tertulis setiap akhir tahun mengenai penggunaan Hak Guna Usaha;
- g. menyerahkan kembali tanah yang diberikan dengan Hak Guna Usaha kepada Negara sesudah Hak Guna Usaha tersebut habis;
- h. menyerahkan sertipikat Hak Guna Usaha yang telah habis kepada Kepala Kantor Pertanahan.

Poin d dan e menentukan membangun dan memelihara prasarana lingkungan dan fasilitas tanah yang ada dalam lingkungan areal Hak Guna Usaha dan memelihara kesuburan tanah, mencegah kerusakan sumber daya alam dan menjaga kelestarian kemampuan lingkungan hidup sesuai dengan peraturan perundang-undangan yang berlaku. Ketentuan ini dapat menjadi landasan HCV dalam areal-areal perkebunan. HCV merupakan fasilitas tanah yang dapat menjaga kelangsungan kelestarian kemampuan lingkungan hidup. Jika kewajiban ini tidak terpenuhi oleh pemilik HGU, maka HGU tersebut dapat dicabut.

HCV dan Hutan Hak

UU No. 41 tahun 1999 tentang Kehutanan dalam pengaturannya memperkenalkan adanya Hutan Hak. Hutan hak adalah hutan yang berada pada tanah yang dibebani hak atas tanah. Pada awalnya, Hutan Hak menjadi bagian yang diatur dalam Peraturan Pemerintah No. 34 Tahun 2002 yang memberikan landasan hukum pada Peraturan Menteri Kehutanan Nomor P.26/Menhut-II/2005 Tentang Pedoman Pemanfaatan Hutan Hak. Peraturan ini mempertegas pengertian Hutan hak sebagai hutan yang berada pada tanah yang telah dibebani hak atas tanah yang dibuktikan dengan alas titel atau hak atas tanah, yang lazim disebut hutan rakyat yang di atasnya didominasi oleh pepohonan dalam suatu ekosistem yang ditunjuk oleh Bupati/Walikota.

Pasal 2 Peraturan Menteri ini menetapkan bahwa tanah yang telah dibebani alas titel atau hak atas tanah berupa sertifikat hak milik, hak guna usaha, dan hak pakai, dapat ditunjuk sebagai hutan hak menurut fungsinya. Penunjukan fungsi hutan hak tersebut berdasarkan pada Rencana Tata Ruang Wilayah Kabupaten/Kota. Hutan hak yang

HCV and RSPO: results of an investigation

telah ditunjuk tersebut memiliki tiga fungsi yaitu a) fungsi konservasi, b) fungsi lindung dan c) fungsi produksi. Kriteria fungsi-fungsi yang dikandung oleh hutan hak tersebut mengacu kepada kriteria yang telah ditetapkan oleh Rencana Tata Ruang Nasional.

Pada tahun 2007, PP No. 34 Tahun 2002 berakhir dan digantikan oleh Peraturan Pemerintah Republik Indonesia Nomor 6 Tahun 2007 dan kemudian pada tahun 2008, PP ini diubah dan ditambah dengan PP No. 3 Tahun 2008. Peraturan Pemerintah No. 6 Tahun 2007 menentukan bahwa hutan hak memiliki fungsi a) konservasi, b) lindung atau, c) produksi. Pemanfaatan hutan hak dilakukan oleh pemegang hak atas tanah yang bersangkutan sesuai dengan fungsinya dan pemanfaatan hutan hak bertujuan untuk memperoleh manfaat yang optimal bagi pemegang hak dengan tidak mengurangi fungsinya. Dalam hal hutan hak tersebut kemudian ditetapkan oleh pemerintah sebagai hutan yang berfungsi konservasi dan lindung maka pemiliknya akan diberikan kompensasi. Konsekuensinya adalah, hutan hak yang berfungsi lindung dan konservasi ini kemudian dapat ditetapkan menjadi kawasan hutan.

Sejauh ini, kebijakan kehutanan terhadap hutan hak masih berorientasi kepada komoditas kayu sehingga aturan yang populer mengenai hutan hak ini adalah aturan pemanfaatan kayu, misalnya Peraturan Menteri Kehutanan Nomor P.33/Menhut-II/2007 Tentang Perubahan Kedua Atas Peraturan Menteri Kehutanan Nomor P.51/Menhut-II/2006 Tentang Penggunaan Surat Keterangan Asal Usul (SKAU) Untuk Pengangkutan Hasil Hutan Kayu Yang Berasal Dari Hutan Hak.

Hutan HCVF dalam areal perkebunan merupakan suatu kesatuan ekosistem berupa hamparan lahan berisi sumber daya alam hayati yang didominasi pepohonan dalam persekutuan alam lingkungannya, yang satu dengan lainnya tidak dapat dipisahkan. Berdasarkan status lahannya, hutan HCVF berada pada lahan Hak Guna Usaha (HGU), sehingga jika merujuk pada pengertian hutan hak yang ditentukan dalam Peraturan Menteri Kehutanan Nomor P.26/Menhut-II/2005, hutan HCVF adalah hutan hak. Namun demikian, kawasan hutan HCVF ini harus mendapatkan penunjukan dari Bupati/Walikota setempat.

Tantangan Hukum HCV Perusahaan Perkebunan

1. Pengalihan status kawasan HCVF kepada perusahaan lain pada masa izin lokasi
2. Pencabutan izin perkebunan karena tidak memenuhi syarat usaha perkebunan

Rekomendasi Hukum

1. Mengawinkan peraturan RSPO dengan Hukum Nasional
2. Perubahan Kebijakan Perkebunan dan Kehutanan Nasional

Annex 4:

Landak District Regulation No. 10 of 2008 on Plantation Business Development (Peraturan Daerah No.10, 2008, tentang Penyelenggaraan Usaha Perkebunan):

Discourages FPIC and justifies repressive land acquisition

Article 15 on land acquisition stipulates that (1) before commencing development activity, company/investor and/or community landowner helped by TP2KP, SATGAS and SATLAK shall first to relinquish the lands that will be developed taking into account rights of landowners and qualify full and appropriate administrative requirements; (2) in case the lands will be developed are subject to customary land rights of customary law community, therefore the applicant of rights shall conduct consultation with the community in order to obtain an agreement on the utilization of the land and its compensation; (3) land clearing is forbidden to destroy and pollute sacred sites, burial grounds, enclave, exceed permitted location boundaries, and shall obey local customs; (4) land clearing and land preparation shall not use fire; and (5) location of land that will be developed shall match with location permit owned by the company.

Location permit (Izin Lokasi)

Article 20 on *Izin Lokasi* stipulates (1) plantation company shall location permit which is issued by Bupati before commencing activities related to estate development; (2) location permit is valid for 3-year period and can be extended 1-year when qualifies requirements; and (3) plantation company which has already have location permit as stipulated above (1) shall conduct real activities on the field within at least six months effectively from permit issuing date.

Article 21 stipulates plantation company which already has location permit shall immediately submit letter of investment approval to head of district (Bupati) through head of district planning agency (BAPEDA) of Landak district.

Article 22 stipulates that plantation company shall conduct Environmental Impact Assessment (Analisis Mengenai Dampak Lingkungan) before commencing plantation development in line with applicable regulation.

Confirms relinquishing of rights

Article 24 on *Hak Guna Usaha (land use right)* stipulates that (1) plantation company shall have land use right (HGU); (2) land use right can be given based on approval letter of granted rights from relevant Minister or official appointed; (3) the provision on procedures and requirements of proposal inquiry to acquire land use right as stipulated under applicable regulations; (4) the land use right for plantation business is given for the period of maximally 35 (thirty five) years and can be extended for the period of maximally 25 (twenty five) years if the evaluation qualifies its obligations provided that the company carries out the plantation management in line with applicable technical regulations; and (5) after the expiry of the land use right period, with an effect of abolishment rights and the ex-land use become state land in line with applicable regulations.

Encourages logging in location permit areas

Article 29 on *Izin Pemanfaatan Kayu dan Izin Pengumpulan Hasil Hutan* (Timber Utilisation Permit and Forest Product Collection Permit) basically allows logging activities to (1) plantation company whose location areas has potential timber and non timber forest product can be utilised shall have permit to utilise the timber and permit to collect non timber forest product and establish partnership with small local enterprise and/or planter community (masyarakat pekebun) and (2) before commencing plantation development activity, the plantation company shall submit an inquiry to get permits to utilise timber and to collect non timber forest product to head of district (Bupati).

Plantation protection

Article 45 on protection stipulates that (1) protection over implementation of plantation development areas are implemented by TP2KP or team appointed by the Bupati; (2) the implementation of plantation protection through persuasive, preventive, and repressive; (3) any agreement made shall be read and signed by both parties; (4) before repressive measures taken as meant in 2 both parties shall have take consultation through TP2K P or team appointed legal enforcers, SATGAS or SATLAK and customary council; (5) plantation company businessperson conduct plantation protection shall be coordinated with security forces and can involve support from communities around plantation areas.

Partnership imposes on smallholders yet less enforcement to company

Unequal rights

Company	Community
<ul style="list-style-type: none"> a. Managing partnership plantation scheme under business use right (HGU), use right and ownership right b. Upon expiry of business use right (HGU) so the extension process subject to applicable regulation c. Rejecting to buy commodity production from small growers if the quality below than standard quality established by government d. Obtaining security and legal certainty; e. Together with local government, TP2KP and communities to manage plantation land use f. Relieving and encouraging small growers to save money and/or join insurance to anticipate replanting costs 	<ul style="list-style-type: none"> a. Obtaining plantation plot or product based on partnership in line with partnership agreement b. Obtaining land certificate based on individual ownership c. Obtaining supervision, development, and information from the company and the government d. Obtaining marketing service and guarantee from plantation company based on market price in line with applicable government regulation and agreed payment schedule e. Obtaining calculation results of their on farm outputs if under joint venture scheme f. Utilising networking roads established for production transportation g. Obtaining representation vote in determining pricing standard for plantation commodity

HCV and RSPO: results of an investigation

Discriminatory obligations

Company	Community
<ul style="list-style-type: none"> a. developing plantation for participating community members altogether at the same time and equal to company plantation out of expected plantation development b. converting right of ownership to participating community members based on partnership agreement in line with technical plantation standards at least on production age c. developing Village Cash Plantation and delegate to village administration d. buying community plantation commodity product based on quality standard and market price in line with applicable regulation e. administering land certificate of land right for community plots and village cash plantation f. establishing connecting road, production road, collection road, and other public facilities based on plantation land use plans and population settlement layout around the plantation in line with recommendations from relevant authority g. conducting social activity in forms of community development around the plantation 2% out of company's profit. h. Conducting development to small grower group and/or cooperative i. Producing an Environmental Impact Assesment (AMDAL) or management plans (UKL)/ monitoring plans in accordance with applicable regulations j. Empowering local community as company workers in line with need k. Helping local government in implementing local development based on terms agreed on the development agreement l. Submitting report to head of district (Bupati) on the plantation progress in every three-month through the district estate crops authority 	<ul style="list-style-type: none"> a. Surrendering lands to plantation company or investor to be developed into partnership plantation and supporting facilities based on size to be specified in the agreed scheme agreement b. Selling all plantation production to plantation company with specified quality based on applicable regulation c. Safeguarding regulation and safety as well as providing support in order to smooth plantation company or investor's activities d. Becoming plantation growers and/or cooperative and comply with cooperation agreement made between local plantation growers and/or cooperative with plantation company or investor.

HCV and RSPO: results of an investigation

<p>m. Providing development, supervision and information to small growers to empower them in strong mastery technical plantation cultivation system.</p>	
--	--

Restriction enforceable to community

Company	Community
<p>1. Plantation company is not allowed to make harmful actions to local community growers or landowners community within during the development time and plantation cultivation.</p> <p>2. Plantation company is prohibited conduct any harmful actions to community growers in buying and establishing production cost</p> <p>3. Plantation company is not allowed to buy community plantation product of other companies without formal request from the company as mentioned.</p>	<p>a. Local plasma growers are not allowed to sell subject to partnership commodity product to other company other than plantation company or investor</p> <p>b. Local plasma growers are not allowed in any reasons and/or any justifications breach partnership agreement</p> <p>c. Plasma growers are prohibited to harm company all along the plantation development and cultivation process</p> <p>d. Plasma growers are prohibited to take plantation product of other owners</p>